

Elevator Technology

# Escalators and moving walks

Escalating performance.



thyssenkrupp



# thyssenkrupp moves people – the future of urban mobility.

In 40 short years, we've become one of the world's leading elevator companies with unique engineering capabilities, offering next-generation solutions like MULTI, the ropeless elevator, ACCEL, an accelerated people mover, and MAX, a cloud-based predictive maintenance service. Whether building a new state-of-the-art system or optimizing and modernizing existing ones, our solutions deliver crucial energy and time efficiencies, helping to address the challenges of urbanization and transform cities into the best places to live.



Figures for our Elevator Technology business

## A trusted partner

We support our customers throughout their project lifecycle, from the design to the end-of-life phase. Every step of the way, we strive to fully understand their needs and consistently deliver the safest, highest quality passenger transportation solutions, maintenance and modernization packages.

Through our internal technical support function, International Technical Services Americas, thyssenkrupp trains its service technicians in a multibrand portfolio, enabling them to successfully service more than 1.2 million units under maintenance.

## thyssenkrupp – the diversified industrial group

engineering.tomorrow.together – three words that describe who we are, what we do, and how we do it. Driven by global megatrends such as urbanization and the need for efficient use of environmental resources, our global community of more than 156,000 colleagues works together with our customers to harness our engineering expertise and strive for technological and business solutions that satisfy the demand for “more” in a “better” way.

Find out more: [www.thyssenkrupp.com](http://www.thyssenkrupp.com)



View from One World Trade Center



Makkah Clock Tower/Source® SL Rasch

We provide smart and innovative products for a wide variety of applications:

- Passenger and freight elevators
- Escalators and moving walks
- Passenger boarding bridges
- Stair and platform lifts
- Customized service and modernization solutions



Mercedes Benz



thyssenkrupp Quartier



## Escalate performance. Optimize traffic.

When you choose an escalator or moving walk, you want to feel confident with the decision you make. You want people you can trust and service you can count on. You want products that last and have minimal impacts on our environment. When you choose thyssenkrupp Elevator, confidence is engineered into everything we do, from the planning and installation process to routine maintenance. It's the reason customers trust us.

# Contents

<b>Escalators</b>	<b>06</b>
Velino – commercial-duty escalator	07
Tugela – heavy-duty escalator	08
Victoria – transit-duty escalator	09
Dimensions and data	10
<b>Escalator modernization</b>	<b>12</b>
<b>Moving walks</b>	<b>14</b>
Orinoco – moving walk	15
iwalk – pit or pit-less moving walks	16
Dimensions and data	17
<b>Design and installation</b>	<b>20</b>
Design options	20
Safety	21
Pre-installation overview	22
Outdoor applications	22
Preparations by others	23
Work by others	26

# Escalators

Be confident in your next step.

thyssenkrupp Elevator offers three classes of escalators, each designed to move people safely and efficiently.



# Velino



## Commercial-duty escalator

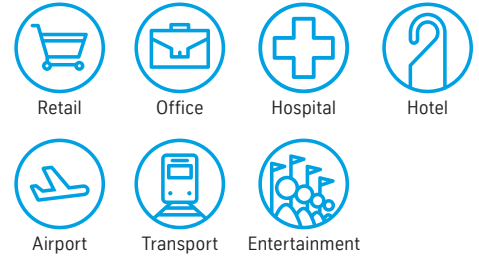

thyssenkrupp Elevator's Velino commercial-duty escalator is designed to preserve the architectural integrity of almost any building. But it's more than just good looks. This machine runs efficiently, keeping daily commuters safe while using minimal energy.

Balustrades of  $\frac{3}{8}$ " (10 mm) thick tempered safety glass panels and optional under-handrail lighting provide striking aesthetics. Dual CPU controllers and optional Variable Voltage Variable Frequency (VVVF) drive technology save energy and lower operational costs.<sup>2</sup>

### Velino – commercial-duty escalator

Rise	Up to 49'-2½" (15 m)
Max capacity (people/hour)	6000
Step load	195 lbs/step <sup>1</sup>
Inclination	27.3° or 30°
Step chain roller	Inside
Location handrail drive	Truss
Handrail shape	U-shape
Climate conditions	Indoor   Outdoor sheltered
Nominal step width	24" (600 mm)   32" (800 mm)   40" (1000 mm)
Speed	100 fpm (0.5 m/s)
Flat steps	2 (minimum per code) or 3 (optional upon request)
Balustrade	Slim   Robust
Aesthetic lights	Balustrade   Skirt   Truss   Ambient cladding   Soffit cladding
Traffic lights	Floor plate   Decking   Column
Safety lights	Step gap   Comb plate
Drive unit	Chain drive
Usage factor	18–20 hours/day
Average life span	20 years

Dimensional data shown here comply with the current ASME A17.1 and CSA B44 Safety Code for Elevators. Local codes may vary from national codes. Consult your local thyssenkrupp Elevator representative for details.

Dimensions above based on 100 fpm.

<sup>1</sup> Minimum ASME requirements assuming 40" step width

<sup>2</sup> Up to 59% energy savings as per Technical Analysis Study Report (TASR)

# Tugela

## Heavy-duty escalator



Retail



Office



Hospital



Hotel



Airport



Transport



Entertainment

Our heavy-duty Tugela escalator is ideal for high-rise applications, convention centers, stadiums, smaller airports or locations with heavy traffic. The reinforced balustrade provides additional strength against bumps from bags and cases. You can customize the look with glass colors and optional under-handrail lighting.

The Tugela features oversized motors, gearboxes and chains. A sprocket-type tension carriage reduces wear on the chain rollers and a handrail pressure system improves handrail drive traction.



### Tugela – heavy-duty escalator

Rise	Up to 72'-2" (22 m)
Max capacity (people/hour)	6000
Step load	Rated for 265 lbs/step <sup>1</sup>
Inclination	27.3° or 30°
Application	High traffic, heavy duty
Step chain roller	Inside
Location handrail drive	Truss
Handrail shape	U-shape   V-shape
Climate conditions	Indoor   Outdoor
Nominal step width	24" (600 mm)   32" (800 mm)   40" (1000 mm)
Speed	100 fpm (0.5 m/s)
Flat steps	2 (minimum per code) or 3 (optional upon request)
Balustrade	Robust   Metal
Aesthetic lights	Balustrade   Skirt   Truss   Ambient cladding   Soffit cladding
Traffic lights	Floor plate   Decking   Newel   Column
Safety lights	Step gap   Comb plate
Drive unit	Chain drive   Direct drive
Usage factor	20–24 hours/day
Average life span	25 years

Dimensional data shown here comply with the current ASME A17.1 and CSA B44 Safety Code for Elevators. Local codes may vary from national codes. Consult your local thyssenkrupp Elevator representative for details.

Dimensions above based on 100 fpm.

<sup>1</sup> Step load per Tugela duty cycle for 40" step



# Victoria



## Transit-duty escalator



Airport



Transport



Entertainment

The Victoria transit-duty escalator is a non-stop workhorse ideal for transport hubs such as train stations and airports. It's our strongest, most powerful escalator and has a reinforced drive system capable of 24/7 maximum performance at full load capacity.

The Victoria features a step chain with external 4" (100 mm) rollers rather than traditional 3" (75 mm) internal rollers. It was developed specifically for transit traffic and comes with metal stainless steel or robust glass balustrades.

### Victoria – transit-duty escalator

Rise	Up to 164' (50 m)
Max capacity (people/hour)	6000
Step load	Rated for 320 lbs/step <sup>1</sup>
Inclination	27.3° or 30°
Application	Transit duty
Step chain roller	Outside
Location handrail drive	Truss   Newel
Handrail shape	U-shape   V-shape
Climate conditions	Indoor   Outdoor
Nominal step width	24" (600 mm)   32" (800 mm)   40" (1000 mm)
Speed	100 fpm (0.5 m/s)
Flat steps	2 (minimum per code), 3 or 4 (optional upon request)
Balustrade	Robust   Metal
Aesthetic lights	Balustrade   Skirt   Truss   Ambient cladding   Soffit cladding
Traffic lights	Floor plate   Decking   (Glass) Newel (high deck balustrade)   Post
Safety lights	Step gap   Comb plate
Drive unit	Chain drive   Direct drive
Usage factor	24 hours/day
Average life span	30+ years

Dimensional data shown here comply with the current ASME A17.1 and CSA B44 Safety Code for Elevators. Local codes may vary from national codes. Consult your local thyssenkrupp Elevator representative for details.

Dimensions above based on 100 fpm. May be modified to suit APTA guidelines.

<sup>1</sup> Step load per APTA guidelines for 40" step

# Dimensions and data

## Side elevation

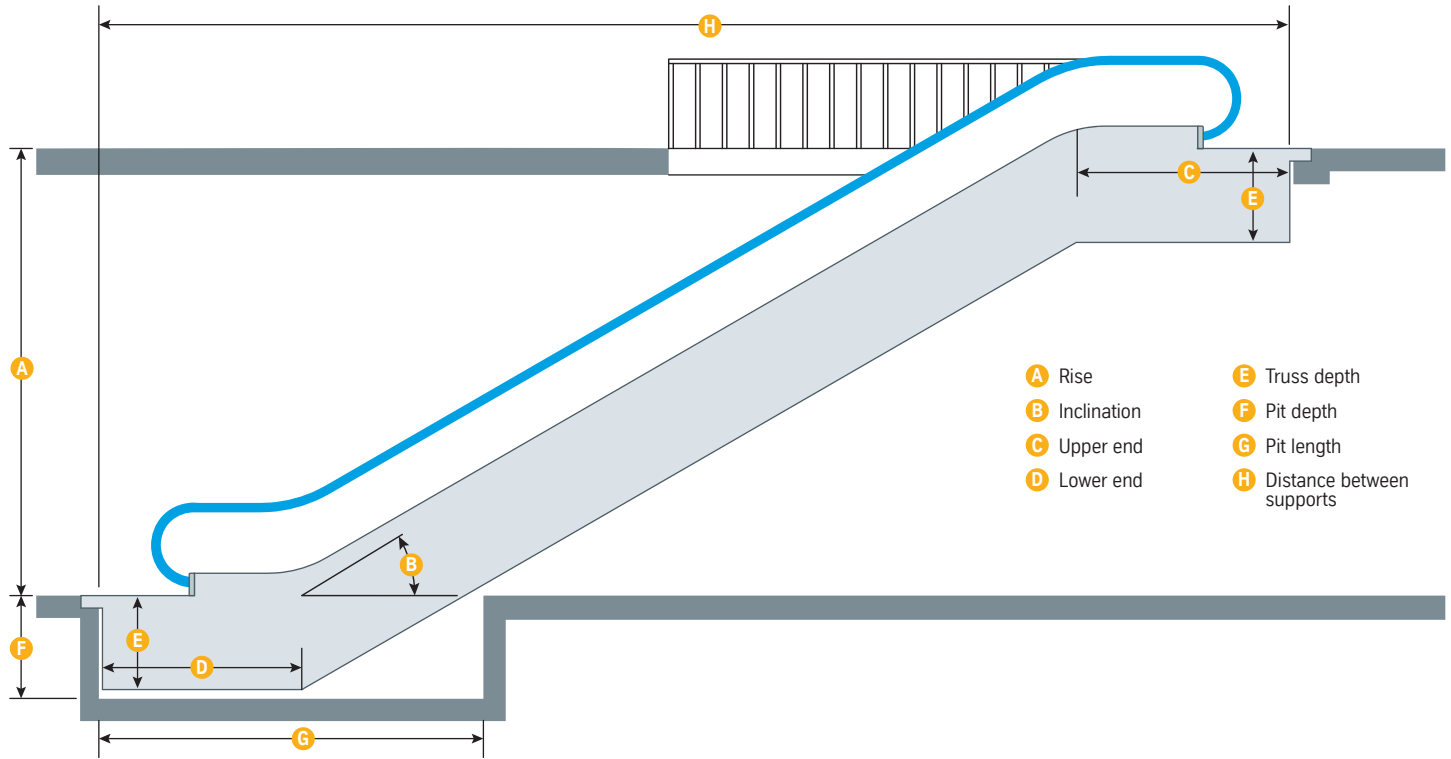

- A** Rise
- B** Inclination
- C** Upper end
- D** Lower end
- E** Truss depth
- F** Pit depth
- G** Pit length
- H** Distance between supports

## Escalators

### Velino

Flat steps	Rise (m) A	Inclination B	Transition radius Top   Bottom (mm)	Upper end (mm) C	Lower end (mm) D	Truss depth (mm) E	Pit depth (mm) F	Pit length (mm) G
2	Up to 49'-2½" (15)	27.3°   30°	3'-5½"   3'-5½" (1050   1050)	8'-2½" (2490)	7'-3" (2210)	3'-5½" (1050)	3'-9¼" (1150)	14'-1½" (4300)
3	Up to 49'-2½" (15)	27.3°   30°	4'-11½"   3'-5½" (1500   1050)	9'-8½" (2950)	8'-6¾" (2610)	3'-5½" (1050)	3'-9¼" (1150)	15'-5½" (4700)

### Tugela

Flat steps	Rise (m) A	Inclination B	Transition radius Top   Bottom (mm)	Upper end (mm) C	Lower end (mm) D	Truss depth (mm) E	Pit depth (mm) F	Pit length (mm) G
2	Up to 72'-2" (22)	27.3°   30°	3'-5½"   3'-5½" (1050   1050)	8'-2½" (2490)	7'-3" (2210)	3'-5½" (1050)	3'-9¼" (1150)	14'-1½" (4300)
3	Up to 72'-2" (22)	27.3°   30°	4'-11½"   3'-5½" (1500   1050)	9'-8½" (2950)	8'-6¾" (2610)	3'-5½" (1050)	3'-9¼" (1150)	15'-5½" (4700)

### Victoria

Flat steps	Rise (m) A	Inclination B	Transition radius Top   Bottom (mm)	Upper end (mm) C	Lower end (mm) D	Truss depth (mm) E	Pit depth (mm) F	Pit length (mm) G
2	Up to 164'-0" (50)	27.3°   30°	4'-11½"   3'-11¼" (1500   1200)	9'-4¾" (2855)	7'-7½" (2315)	3'-9¼" (1150)	4'-0½" (1220)	14'-5¼" (4400)
3	Up to 164'-0" (50)	27.3°   30°	8'-6¾"   6'-6¾" (2600   2000)	11'-7¾" (3550)	9'-7 ⅜" (2930)	3'-9¼" (1150)	4'-0½" (1220)	16'-5½" (5015)
4	Up to 164'-0" (50)	27.3°   30°	9'-10½"   7'-2¾" (3000   2200)	14'-10½" (4525)	11'-10½" (3610)	3'-9¼" (1150)	4'-0½" (1220)	18'-9½" (5730)

Dimensional data shown here comply with the current ASME A17.1 and CSA B44 Safety Code for Elevators. Local codes may vary from national codes. Consult your local thyssenkrupp Elevator representative for details.

Dimensions above based on 100 fpm. May be modified to suit APTA guidelines.

## Cross-section

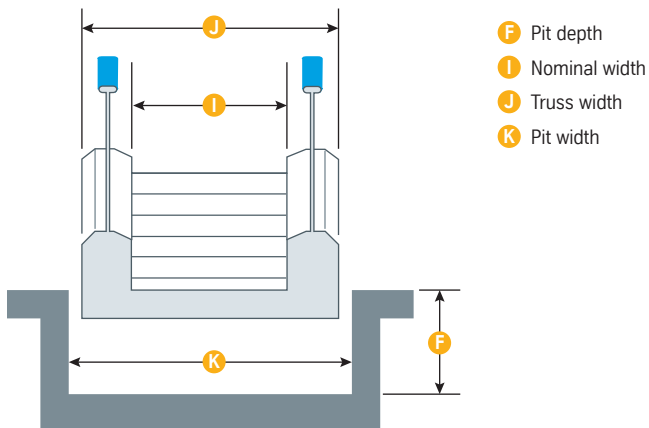

- F** Pit depth
- I** Nominal width
- J** Truss width
- K** Pit width

## Velino/Tugela

Nominal step width (mm) I	Truss width (mm) J	Pit width (mm) K	Persons per hour 100 fpm (0.5 m/s)
24" (600)	3'-8½" (1130)	3'-10⅞" (1190)	3600
32" (800)	4'-4⅜" (1330)	4'-6¾" (1390)	4800
40" (1000)	5'-0¼" (1530)	5'-2⅝" (1590)	6000

## Victoria

Nominal step width (mm) I	Truss width (mm) J	Pit width (mm) K	Persons per hour 100 fpm (0.5 m/s)
24" (600)	4'-07½" (1230)	4'-2⅜" (1290)	3600
32" (800)	4'-8⅝" (1430)	4'-10⅜" (1490)	4800
40" (1000)	5'-4⅜" (1630)	5'-6⅝" (1690)	6000

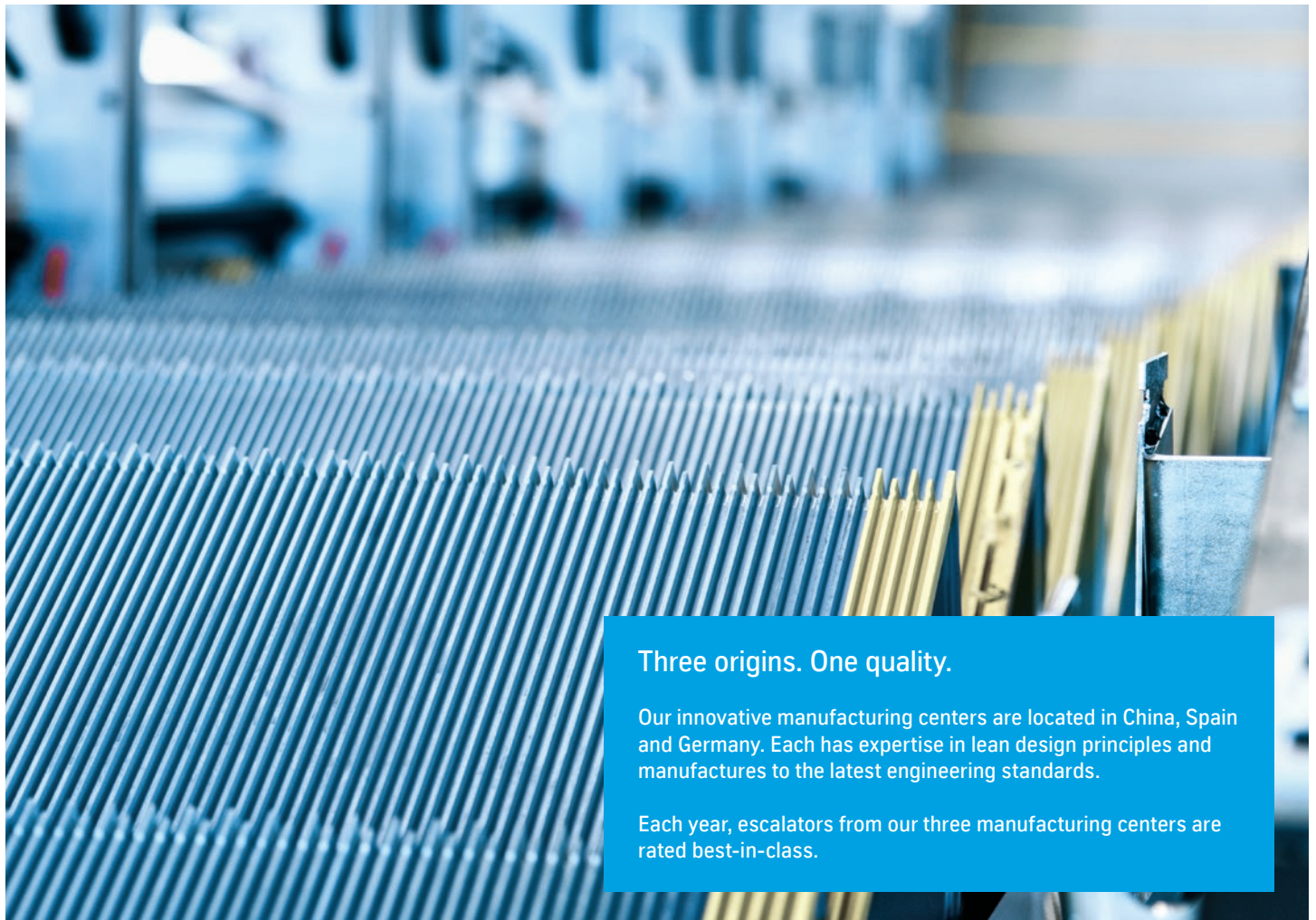

## Three origins. One quality.

Our innovative manufacturing centers are located in China, Spain and Germany. Each has expertise in lean design principles and manufactures to the latest engineering standards.

Each year, escalators from our three manufacturing centers are rated best-in-class.

# Escalator modernization

Achieve optimum efficiency.

Modernizing your escalator is the most effective way to improve its performance while reducing its energy consumption and costs. Your modernized escalator will meet the latest code while gaining improved safety and reliability.



# ES-Power modernization process



To modernize your escalators, an entirely new escalator is built within the existing steel truss. You can expect a reduction in energy use. thyssenkrupp Elevator also will work to use much of your existing equipment to reduce waste and lower your costs.

With our ES-Power modernization package, we can use most existing trusses, regardless of manufacturer. The existing truss will be cleaned, repainted and prepared for installation of the modernization component package.

As part of the modernization, your escalator will be brought to current ASME code standards, and will receive more than 15 safety devices.

**With ES-Power modernization package, the following components are replaced:**

- Floor plates
- Comb plate assemblies
- Handrails
- Handrail drive system
- Balustrades, skirts, deckings
- Mounting hardware
- Steps, chains, axles, rollers
- Step tracks and track supports (structure or truss is the only item retained)
- Motor, gearbox and brake
- Main drive sprocket assembly
- Lower tension carriage systems
- Controls, piping and electrical equipment

## Install step 1 – Disassembly



Remove existing components and clean truss to prepare the base for the new escalator.

## Install step 2 – Installation



Install components, including electrical cabinet and distribution boxes. Align new upper and lower modules using adjusting tools.

## Install step 3 – Middle segment

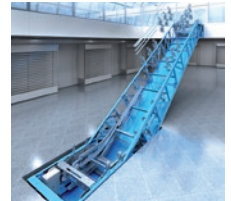

Install central modules, track system and step band. Align to ensure a perfect fit.

## Install step 4 – Aesthetic upgrade



Install visible components such as balustrade, decking, cladding, if applicable, and floor plates to make escalator look like new.

## Install step 5 – Test and commissioning



Perform site acceptance test and commissioning.

# Moving walks

Long stretches become shorter.

Help passengers take a break or speed their pace. Our moving walks use conveyor technology to keep people safe as they move to their destination.



# Orinoco



## Moving walk



Airport



Transport



Entertainment

Orinoco moving walks are dependable with design options allowing the equipment to harmonize with any architecture.

All balustrade configurations (stainless steel metal or glass Robust and Slim) ensure a perfect integration with your building.

Special widths [including the 63" (1600 mm)] allow large volumes of passengers carrying luggage, with the space to safely pass standing passengers.

### Orinoco – moving walk

Max length   Rise	Up to 656'-2" (200 m)
Max capacity (people/hour)	8200
Inclination	0° – 6°   10°   12°
Configuration	Pit
Application	Commercial   Traffic
Step chain roller	Inside
Location handrail drive	Truss
Handrail shape	U-shape   V-shape
Climate conditions	Indoor   Outdoor
Nominal step width	32" (800 mm)   40" (1000 mm)   48" (1200 mm)   55" (1400 mm)   63" (1600 mm)
Speed	100 fpm (0.5 m/s)   120 fpm (0.65 m/s)   150 fpm (0.75 m/s)
Balustrade	Slim   Robust   Metal   Sandwich
Aesthetic lights	Balustrade   Skirt   Truss   Ambient cladding   Soffit cladding
Traffic lights	Floor plate   Decking   Newel   Column
Safety lights	Step gap   Comb plate
Drive unit	Chain drive   Direct drive
Usage factor	18 hours/day
Average life span	25 years

Dimensional data shown here comply with the current ASME A17.1 and CSA B44 Safety Code for Elevators. Local codes may vary from national codes. Consult your local thyssenkrupp Elevator representative for details. Dimensions above based on 100 fpm (0.5 m/s).

# iwalk

## Pit or pit-less moving walk



Airport



Transport



Entertainment

iwalk, our moving walk, fits anywhere. The slim dimensions require very little construction work, and technical features ensure low energy consumption. This walk is compact enough to allow installation on buildings in operation.

The horizontal iwalk needs only a shallow 15" (380 mm) pit, or can be installed on top of an existing floor. All that's needed for installation are two ramps at each end.

For pit-less applications, it can be easily relocated to different parts of the building depending on traffic needs. It can also be shortened or enlarged.

Thanks to a small and flat comb plate, the risk of tripping is reduced. Unlike traditional moving walks, these seamless transitions allow easy travel with luggage trolleys, strollers or shopping carts.

iwalk incorporates the latest energy-efficient technology including soft-starting, VVVF technology and exclusive LED lighting. And it's lubrication-free, eliminating the risk of spills.

### Advantages at a glance:

- Easy to adapt and install
- Lightweight, modular and flexible installation
- Innovative pallet band with efficient drive provides a smooth, safe ride
- Pit-less configuration allows easy relocation and length modification
- Advanced design with no visible screws throughout the moving walk
- Longer balustrades and wider pallets maintain exterior dimensions
- Low risk of passenger tripping due to reduced comb segment height
- Increased inner pallet width allows easy passing for passengers with luggage
- Variable speed operation also available



### iwalk – pit or pit-less moving walk

Max length   Rise	Up to 328' (100 m) <sup>1</sup>
Max capacity (people/hour)	7300
Inclination	0° – 6°
Configuration	Shallow pit   Pitless
Application	Commercial   Traffic
Step chain roller	Not applicable
Location handrail drive	Truss
Handrail shape	U-shape
Climate conditions	Indoor   Outdoor
Nominal step width	44" (1100 mm)   55" (1400 mm)
Speed	100 fpm (0.5 m/s)   120 fpm (0.65 m/s)
Balustrade	Slim
Aesthetic lights	Balustrade   Skirt
Traffic lights	Floor plate   Front skirt   Post
Safety lights	Step gap
Drive unit	Direct drive
Usage factor	18 – 20 hours/day
Average life span	15 – 20 years

Dimensional data shown here comply with the current ASME A17.1 and CSA B44 Safety Code for Elevators. Local codes may vary from national codes. Consult your local thyssenkrupp Elevator representative for details. Dimensions above based on 100 fpm (0.5 m/s). <sup>1</sup> Reversible only for lengths under 200 feet (61 m) long.



# Dimensions and data

## Orinoco moving walks

### Horizontal orientation

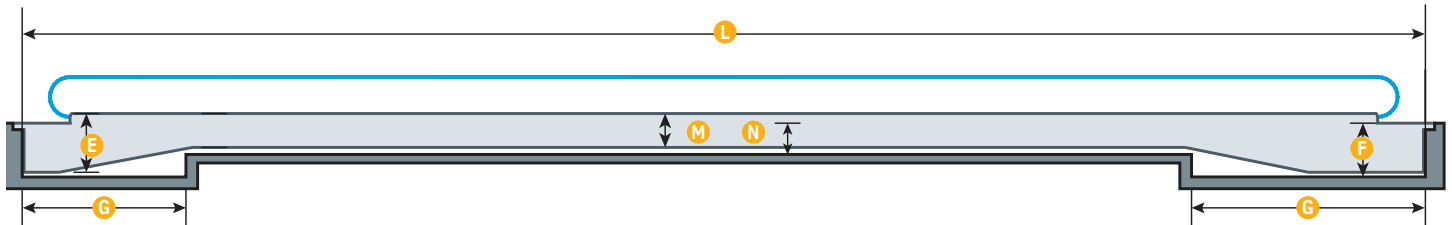

### Inclined orientation

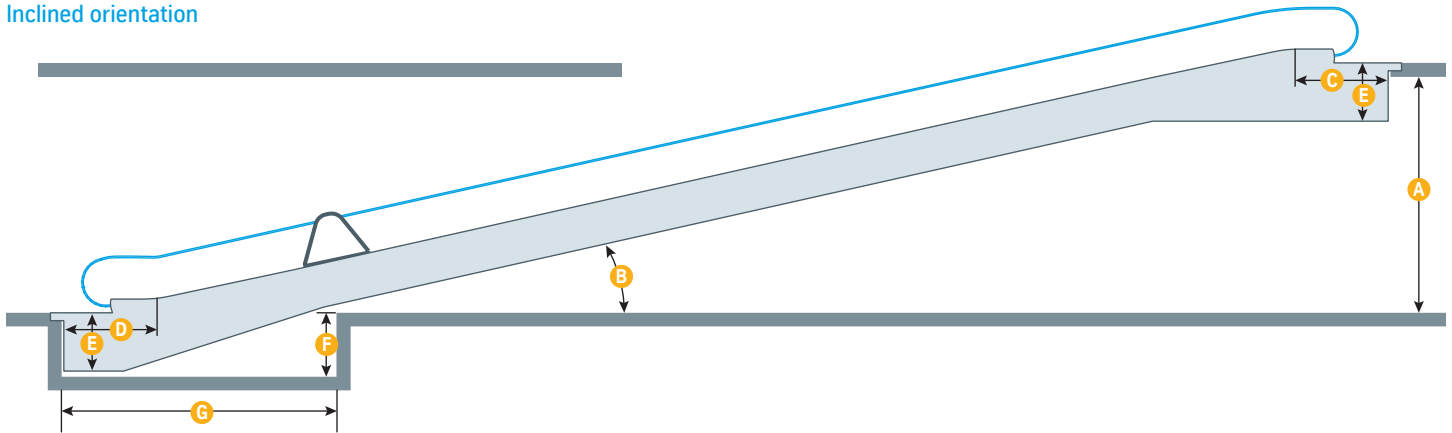

### Cross-section

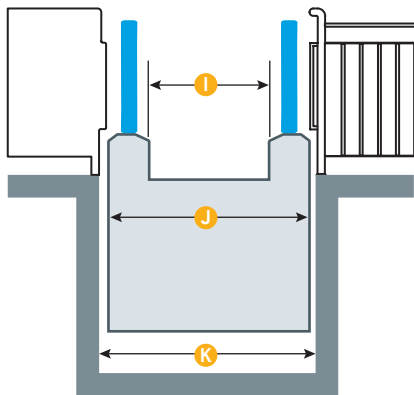

- A** Rise
- B** Inclination
- C** Upper end
- D** Lower end
- E** Truss depth
- F** Pit depth
- G** Pit length
- I** Nominal width
- J** Truss width
- K** Pit width
- L** Length
- M** Middle part truss depth
- N** Middle part pit depth

### Orinoco moving walks

	Horizontal	Inclined
A – Rise (m)	N/A	Up to 19'-8¼" (6)
B – Inclination	0° – 6°	10°   12°
C – Upper end (mm)	N/A	9'-1¾" (2790)
D – Lower end (mm)	N/A	10'-0½" (3060)
L – Length (m)	Up to 656'-2" (200)	N/A
E – Truss depth (mm)	3'-5⅝" (1050)	3'-5⅝" (1050)
F – Pit depth (mm)	3'-9¼" (1150)	3'-9¼" (1150)
G – Pit length (mm)	18'-0⅞" (5500)	20'-0⅜" (6100)
M – Middle part truss depth (mm)	1'-8½" (520)	N/A
N – Middle part pit depth (mm)	2'-2⅞" (670)	N/A

Nominal pallet width (mm)	Truss width (mm)	Pit width (mm)	Persons per hour at 100 fpm (0.5 m/s)	Persons per hour at 125 fpm (0.65 m/s)	Persons per hour at 150 fpm (0.75 m/s)
I	J	K			
32" (800)	4'-4⅞" (1330)	4'-6¾" (1390)	4800	5900	6600
40" (1000)	5'-0¼" (1530)	5'-2⅝" (1590)	6000	7300	8200
48" (1200)	5'-8½" (1740)	5'-10⅞" (1800)	6000	7300	8200
55" (1400)	6'-4⅞" (1940)	6'-6¾" (2000)	6000	7300	8200
63" (1600)	7'-0⅞" (2148)	7'-3" (2208)	6000	7300	8200

# Dimensions and data

## iwalk moving walk

### Shallow pit configuration

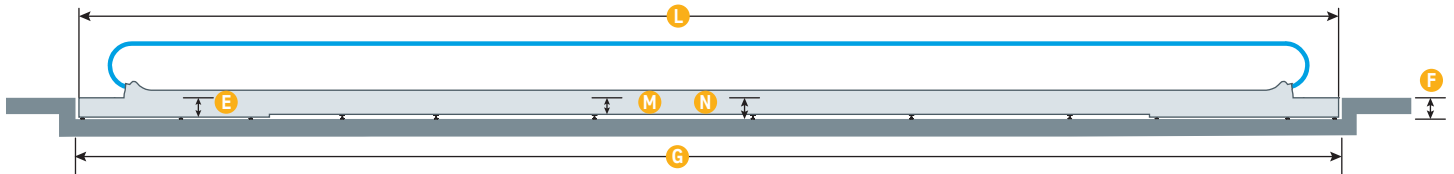

### Pitless configuration

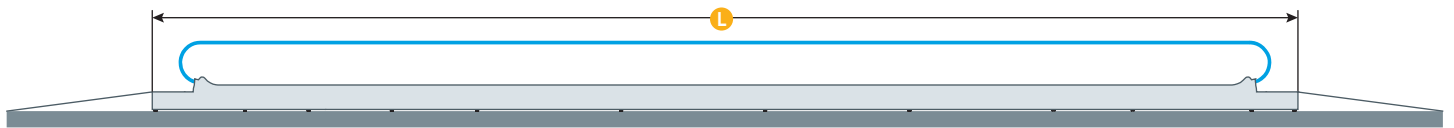

### Cross-section

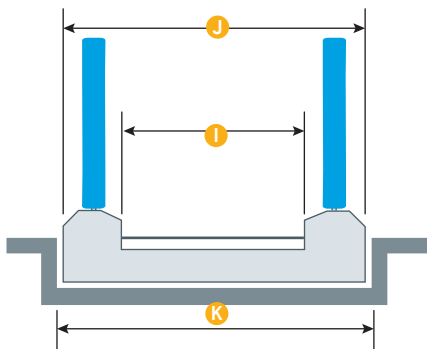

- E** Truss depth
- F** Pit depth
- G** Pit length
- I** Nominal width
- J** Truss width
- K** Pit width
- L** Length
- M** Middle part truss depth
- N** Middle part pit depth

### iwalk moving walks

	Shallow pit	Pitless
A – Rise (m)	N/A	N/A
B – Inclination	0° – 6°	0° – 6°
L – Length (m)	Up to 328'-0" (100)	Up to 328'-0" (100)
E – Truss depth (mm)	1'-2 <sup>3</sup> / <sub>16</sub> " (360)	N/A
F – Pit depth (mm)	1'-3" (380)	N/A
G – Pit length (mm)	Continuous	N/A
M – Middle part truss depth (mm)	1'-2 <sup>3</sup> / <sub>16</sub> " (360)	N/A
N – Middle part pit depth (mm)	1'-3" (380)	N/A

Nominal pallet width (mm)	Truss width (mm)	Pit width (mm)	Persons per hour at 100 fpm (0.5 m/s)	Persons per hour at 125 fpm (0.65 m/s)
I	J	K		
44" (1118)	4'-10 <sup>15</sup> / <sub>16</sub> " (1497)	5'-1 <sup>9</sup> / <sub>16</sub> " (1565)	6000	7300
55" (1397)	5'-11 <sup>1</sup> / <sub>16</sub> " (1805)	6'-17 <sup>1</sup> / <sub>16</sub> " (1865)	6000	7300

Dimensional data shown here comply with the current ASME A17.1 and CSA B44 Safety Code for Elevators. Local codes may vary from national codes. Consult your local thyssenkrupp Elevator representative for details.

Dimensions above based on 100 fpm (0.5 m/s).



With our top-class, innovative solutions for elevators, escalators and moving walks, we help you shape the buildings of the future – as you want them to be. With endless possibilities.

# Design options

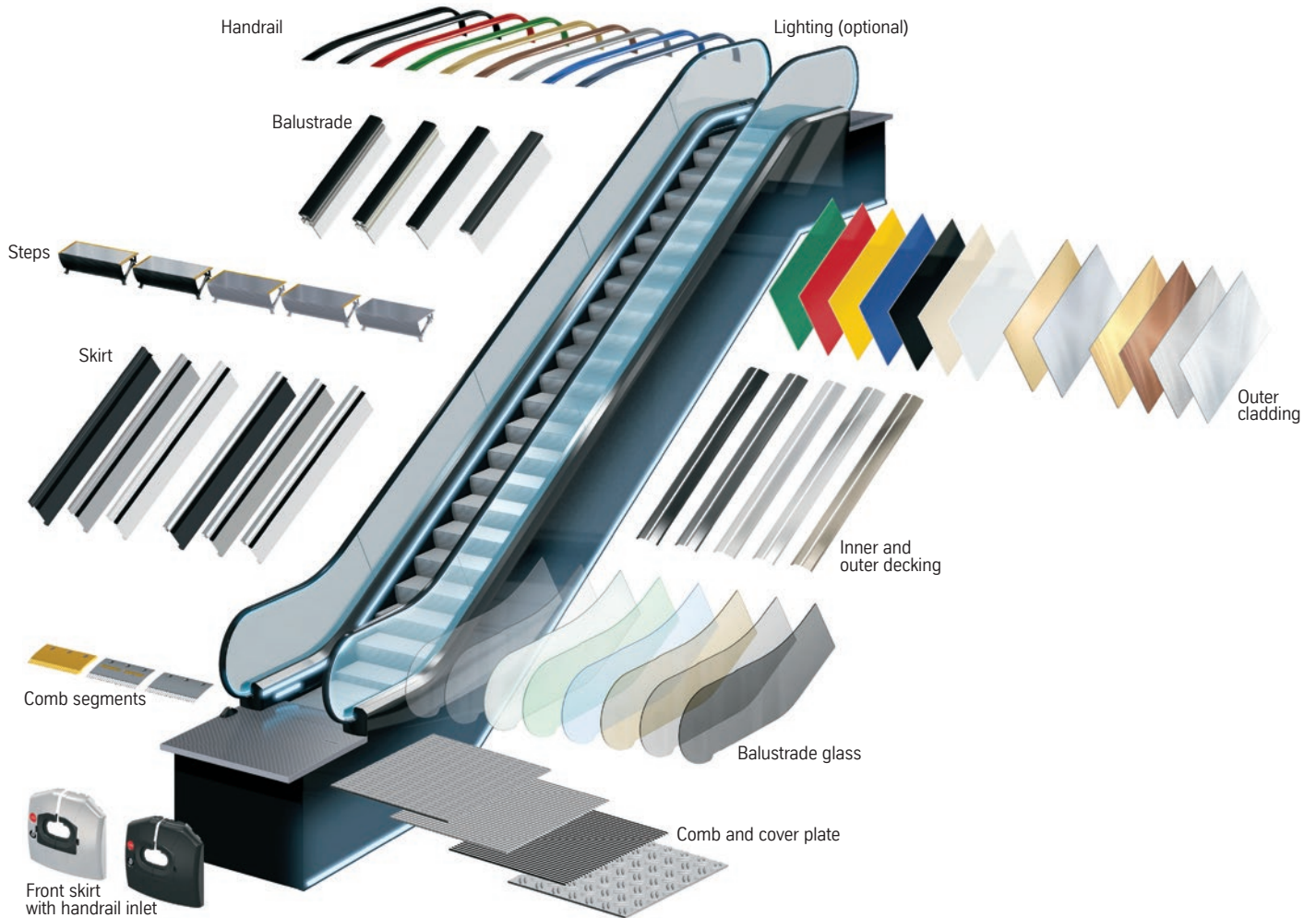

Customize your escalator using our many design options. Our experts are available to help you create an escalator that's as unique as your project.

## Outer Cladding

Our cladding has nearly invisible joints, screws and rivets. A variety of colors and finishes are available, including gold, copper and ultramarine.

## Balustrade glass

Tempered safety glass is available in a wide range of colors, including clear, azure, bronze and dark gray.

## Handrail

The cover is made either of black synthetic rubber or thermoplastic elastomers (TPE) in five standard colors and three special colors. Additional colors or laser-print branding are available on request.

## Comb and cover plate

Customizable combs and cover plates provide a non-slip tread. Options include stainless steel or aluminum with different surface finishes.

## Inner and outer decking

Choose between stainless steel or aluminum. Aluminum comes in five standard colors as well as additional colors upon request.

## Steps

Comes in two standard configurations – silver or black with yellow demarcation lines. However, any other color is possible upon request.

# Safety

## Safety Zone

The entry and exit zone must always be kept clear of obstacles. The width must not be less than the width between the centerlines of the handrail plus 8" (200 mm).<sup>1</sup>

The length of the zone, measured from the end of the newel, must be no less than twice the distance between the centerlines of the handrail. Space must be provided to accommodate all traffic in the safety zone.

Safety zones		
Step width	Safety zone width Y	Safety zone length Z
24" (600 mm)	3'-5" (1038 mm)	5'-6" (1676 mm)
32" (800 mm)	4'-1" (1242 mm)	6'-10" (2084 mm)
40" (1000 mm)	4'-9" (1446 mm)	8'-2" (2492 mm)

## Skirt brushes

Prevents passenger foot entrapment within the step/skirt running clearance. These are featured on all thyssenkrupp escalators.

## Headroom clearance

The clearance above the step or pallet band must be at least 7'-0" (2134 mm) at every location as required by code.

Safety zone (no infill panels)

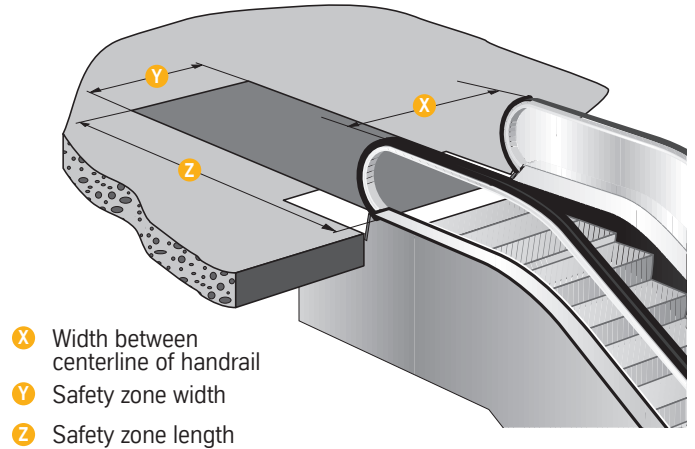

- X Width between centerline of handrail
- Y Safety zone width
- Z Safety zone length

## Lighting

For passengers to step safely onto escalators, the step or pallet band must be adequately lit. The ambient building lighting must be at least 50 lux along all parts of the step band. thyssenkrupp Elevator offers various lighting options, including:

- Above the balustrade (under handrail)
- Integrated in the skirt band
- At the comb plate

Escalator safety features									
Motion safety	Standard	Option	Proactive safety	Standard	Option	Component protection	Standard	Option	
Operational brake on the motor	✓		Fire alarm shutdown switch <sup>2</sup>		✓	Phase sequence relay	✓		
Auxiliary brake on the motor or mainshaft <sup>2,3</sup>	✓		Anti-climbing device <sup>2</sup>	✓	✓	Brake function monitoring	✓		
Step up-thrust device	✓		Comb plate lighting		✓	Brake wear monitoring		✓	
Comb plate switch horizontal	✓		Fall protection <sup>2</sup>		✓	Step chain tensioning switch	✓		
Comb plate switch vertical	✓		Protecting gratings	✓		Cover plate open contacts		✓	
Emergency stop with cover on alarm <sup>2</sup>	✓		Skirt brushes or rubber deflectors	✓		Drive chain monitoring <sup>2</sup>	✓	✓	
Handrail inlet with flap system	✓		Step gap lighting	✓		Handrail broken device/derailment detection		✓	
Skirt micro switches	✓		Bi-color traffic lights in inner decking		✓	Missing step monitoring	✓		
<b>Building interfaces</b>			Bi-color traffic lights in front of cover plates		✓	Motor speed monitoring	✓		
Bollards		✓	Yellow comb segments	✓		Handrail speed monitoring	✓		
Sprinklers		✓	Step demarcation lines	✓		Step run guard	✓		
Deflectors, e.g. for ceilings		✓				Earthquake lock <sup>2</sup>		✓	
Deflectors at the handrail newel		✓				Wire protection in truss		✓	
						30 mA FI protection	✓		
						Full motor protection	✓		

<sup>1</sup> These dimensions are absolute minimums. An infill panel must be installed.

<sup>2</sup> Depending on local code requirements

<sup>3</sup> Standard above 6m

# Pre-installation overview

## Travel speeds and transport capacities

Escalators and moving walks continuously move passengers, giving them greater transport capacity than elevators.

Travel speed of escalators is limited by code to 100 fpm (0.5 m/s). For moving walks with 0° – 8° inclination, the speed can be increased up to 180 fpm (0.9 m/s).

## Travel heights and inclines

**Escalators:** With a rise of only 6'-0" (1829 mm), an escalator can considerably improve building access. thyssenkrupp Elevator has designed escalators to reach a rise of 164'-0" (50 m). Code limits the inclination angle to 30° in the United States and Canada. A minimum of two flat steps is required at both landings per ASME code. Special design for three flat steps or more can be provided if requested.

**Moving Walks:** Inclined moving walks in shopping centers and retail applications are permitted a maximum angle of 12°. For extended travel distances, such as trade fairs and airports, horizontal moving walks allow wider pallets, and are the most efficient option.

## Step/Pallet widths

Step/Pallet width refers to usable interior space (skirt to skirt) for passengers. The most demanding step width in the USA and Canada is 40" (1016 mm) to allow two rows of passengers. In locations with space restrictions, 32" (800 mm) or 24" (600 mm) can be installed.

The predominant use of moving walks is in airports where passengers carry hand luggage, making the 55" pallet width the preferred solution.

Two flat step configuration

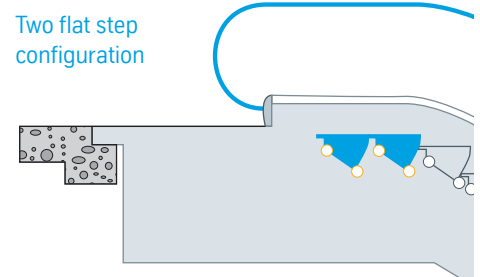

Three flat step configuration\*

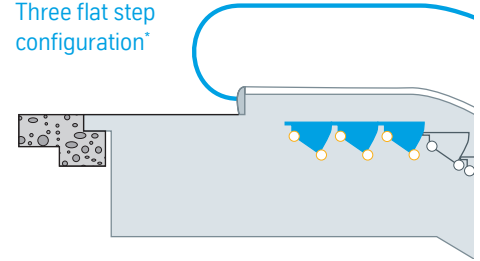

\* Three flat step configuration under request only.

# Outdoor applications

## Designed for all weather conditions

Our outdoor application escalators and moving walks maintain performance and reliability in all weather conditions, including extreme heat and below-freezing temperatures. There are no limitations on features and customizations.

## All-weather features

Rugged features such as protective chain covers, automatic lubrication and truss corrosion protection protect your equipment and ensure reliable performance.

## Designed for passenger safety

Optional heating systems prevent ice formation on steps and floor plates, helping maintain the equipment while ensuring safe conditions for passengers.



# Preparations by others



When possible, schedule your escalator delivery before installing floor slabs, ceilings, roofs or any overhead obstructions.

Normally, completely assembled escalators or moving walks are moved in by crane through a suitable overhead opening.

In most cases, this allows the equipment to be assembled off site, removing disruptions to other subcontractors. Another option is bringing the escalator or moving walk in through a suitable opening at the ground floor. It's important that the route to the assembly location within the building be free of obstacles and level. The ceiling should also be able to support the hoist load. Otherwise, appropriate shoring must be provided.

Ensure the building floor can bear the escalator's transport weight. Otherwise, additional floor underpinning support is required during installation.

To have your system delivered and assembled in a timely manner, please take note of the following while planning:

- When it's not possible to bring a complete escalator or moving walk into the building, the balustrade must be dismantled before delivery.
- The length of some escalators or moving walks require their manufacturing with a split and installation in sections.

You'll be notified of the location and size of required ceiling and roof openings. Please ensure the required opening dimensions are available.

When designing support recesses, take into account the support loads. They're shown on the installation drawing. At those locations where escalator or moving walk supports will be placed, the supports must be able to bear the weight including 105 lbs/ft<sup>2</sup> traffic load. When preparing the supporting structures, the dimensions and reactions on our installation plans must be precisely met.

Intermediate supports are needed on escalators with a considerable travel height and on long moving walks. You'll be informed if an intermediate support is required. We'll assist with determining the proper location.

Typically, the following intermediate support is required:

- Two flat steps design:  $H > 26'-6''$  (8077 mm)
- Three flat steps design:  $H > 24'-10''$  (7569 mm)

Completely assembled escalator

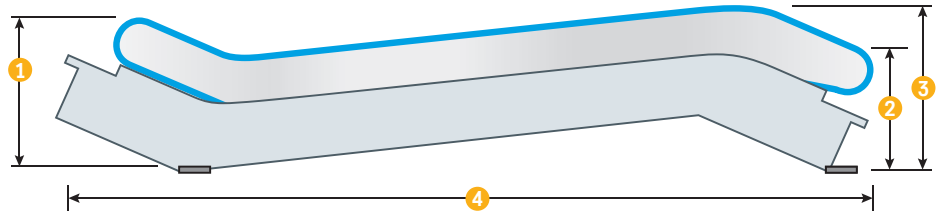

Split escalator

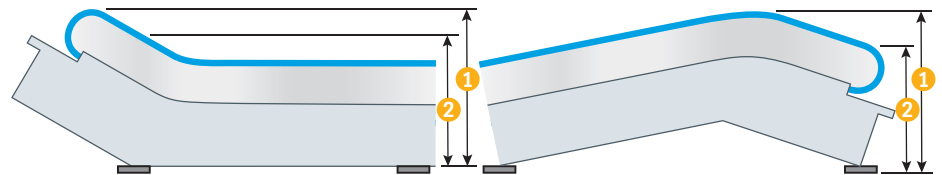

Top and bottom supports

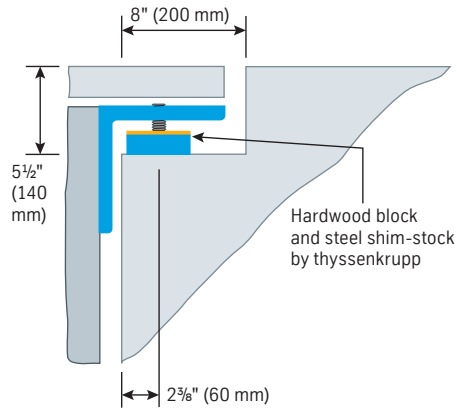

- 1 Transport height with balustrade
- 2 Transport height with balustrade removed
- 3 Transport height with upper balustrade removed
- 4 Transport length
- 5 Floor-to-floor height

Intermediate supports

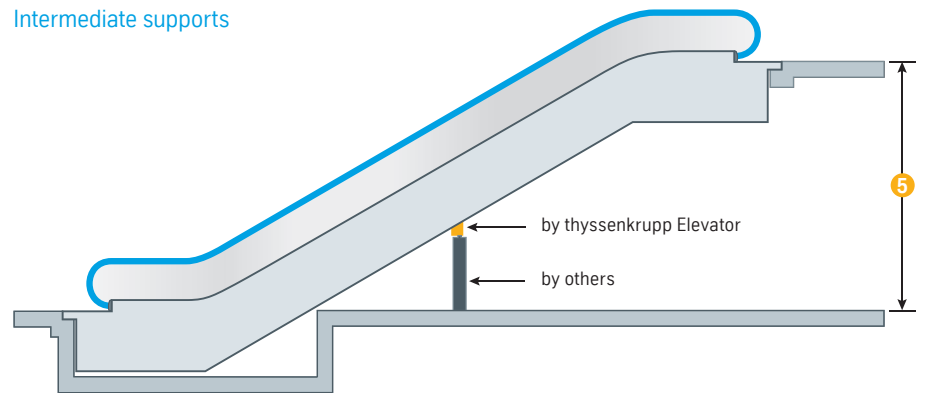



Pick-up points with wooden beam

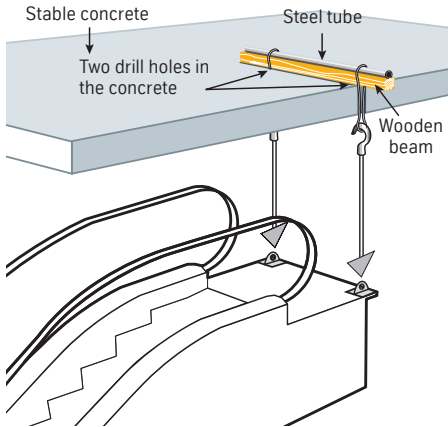

You'll be responsible for fitting pick-up points plus hoisting and supporting the escalator during assembly. Speak to your local thyssenkrupp Elevator representative for size and location. These should be located exactly above the center of the supporting points. For systems with several supporting structures, please plan for additional pick-up points above the intermediate supports. All pick-up points must be capable of taking a load strain of 11,240 lbs (50 kN).

The exterior cladding of the truss is prepared by others unless otherwise specified. Weight of the cladding must not exceed 5 lb/ft<sup>2</sup> (25 kg/m<sup>2</sup>).

installed in this separate control room. For additional soffit lighting, a separate power supply must be provided. The power connection must be provided by an authorized electrician assigned by the owner's representative. If escalator truss or comb plate heaters are provided, a separate 220 VAC power supply is required.

An optional safety feature is the installation of a sprinkler piping within the escalator or moving walk.

A type-proofed oil / water separator is essential for escalators and moving walks with outdoor exposure. thyssenkrupp supplies an oil / water separator in the lower well for all outdoor-exposure products. At the construction site, a recess and drain must be provided for the oil separator in the pit.

Pick-up points with threaded rods

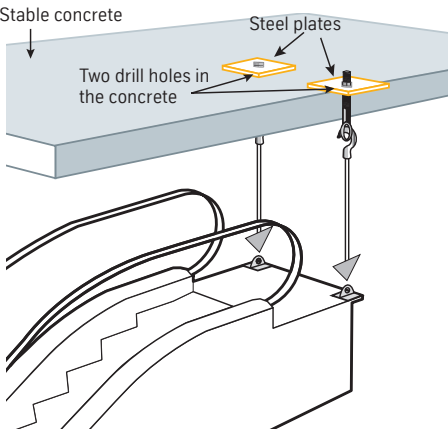

Our diagram shows where escalators and moving walks are connected to the power supply. The power supply is always located at the upper well. Electrical cables are inserted at a distance of 1'-6" (450 mm) on the side of the support and the length of the cable inside of the escalator must be about 5'-0" (1500 mm).

With complex controls, such as those required in transit installations, the escalator control equipment may be installed in a separate room. The power supply cable must be

In the escalator threshold areas, a railing must be installed by others. The distance to the escalator handrail must be at least 4" (100 mm).

Electrical connections

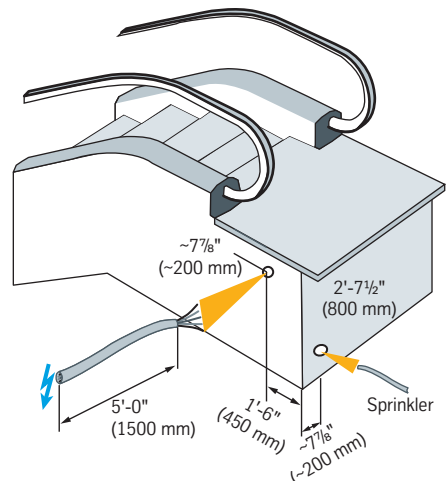

For outdoor exposed escalators

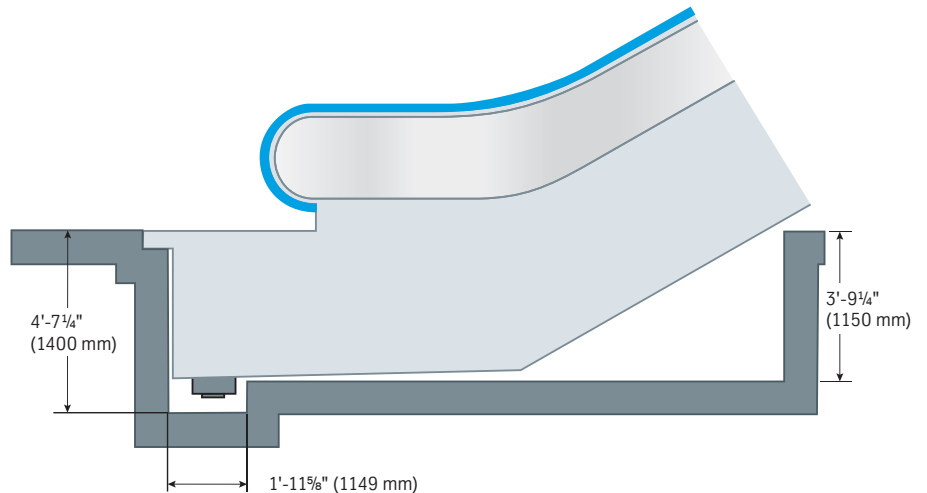

# Required work by other trades

## Escalators

- Provision of proper building dimensions and suitable floor openings, properly framed with suitable reactions and finished in accordance with escalator shop drawings. Variations not to exceed 1" at any point.
- Supporting structure for escalators and enclosure walls, external railing, guards, closures, shutters and smoke barriers as required.
- Waterproofed lower well space and lower pit drainage as required.
- Fire-rated exterior cladding of truss and finish from the edges of escalator deck covers, including ends, sides and bottom of truss in accordance with applicable and standard weight restrictions (max. 5 lbs per square foot).
- Access panels or doors to interior of escalator if required by unusual layout conditions.
- Provision of flexible in-fill and finished flooring next to floor plates and escalator after installation.
- Cutting of floors, walls, ceilings or partitions together with any repairs made necessary by such cutting.
- Painting and finish work required beyond that included in this section.
- Electrical service to upper well including three-phase main power supply and lockable, fused disconnects to each controller. Provide single-phase 120 VAC electrical service and lockable, fused disconnect for light and convenience outlet in the upper well and all other electrical devices that are not a part of the escalator proper but may be required by local authorities. Separate 220V AC to be supplied with lockable, fused disconnect for truss or comb plate heating when required.
- Provision of wiring and conduit from the closest wellway of each escalator group or single escalator to the firefighters' control room or console as required. Coordinate with escalator contractor for size, number and location of conduit.
- Other work required for installation of the escalator(s) including, but not limited to, required changes to sprinklers, lighting, electrical, air conditioning and heating systems. Provide barriers for open wellways during construction per OSHA regulations.
- Protection of escalator truss, steps, landing plates, balustrades, handrail and special metal finishes from damage during construction.

## Moving walks

- Provision of proper building dimensions and suitable floor openings, properly framed with suitable reactions and finished in accordance with moving walk shop drawings. Variations not to exceed 1" at any point.
- Supporting structure for the moving walks and enclosure walls, external railing, guards, closures, shutters and smoke barriers as required.
- Waterproofed lower well space and lower pit drainage as required.
- Fire-rated exterior cladding of truss and finish from the edges of moving walk deck covers, including ends, sides and bottom of truss in accordance with applicable and standard weight restrictions (max. 5 lbs per square foot).
- Access panels or doors to interior of moving walk if required by unusual layout conditions.
- Provision of flexible in-fill and finished flooring next to floor plates and moving walk after installation.
- Cutting of floors, walls, ceilings or partitions together with any repairs made necessary by such cutting.
- Painting and finish work required beyond that included in this section.
- Electrical service to upper well including three-phase main power supply and lockable, fused disconnects to each controller. Provide single-phase 120 VAC electrical service and lockable, fused disconnect for light and convenience outlet in the upper well and all other electrical devices not a part of the moving walk proper that may be required by local authorities.
- Provision of wiring and conduit from the closest wellway of each moving walk group or single moving walk to the firefighters' control room and console as required. Coordinate with moving walk contractor for size, number and location of conduit.
- Other work required for installation of the moving walk(s) including, but not limited to, required changes to sprinklers, lighting, electrical, air conditioning and heating systems. Provide barriers for open wellways during construction per OSHA regulations.
- Protection of moving walk truss, steps, landing plates, balustrades, handrail and special metal finishes from damage during construction.
- All engineering costs to determine and identify structural load capacities and restrictions will be by others.



# Elevator Technology

thyssenkrupp Elevator Corporation  
2591 Dallas Parkway, Suite 600  
Frisco, TX 75034, USA  
P: +1 844 427 5461  
www.thyssenkruppelevator.com



engineering.tomorrow.together.

All illustrations and specifications are based on information in effect at time of publication approval.  
thyssenkrupp Elevator reserves the right to change specifications or design and to discontinue items without prior notice or obligation.  
© 2018 thyssenkrupp Elevator Corporation. CA License #C11-651371 | 8274 | Escalator product guide catalog