



Schindler 9300AE

The world's leading escalator for safe and reliable passenger transport.





With your needs in mind

Schindler 9300AE

▶▶▶ Your safety, our responsibility

The Schindler 9300AE escalator is designed to meet the highest standards in the industry. We ensure that each passenger enjoys a safe ride.

▶▶▶ Energy-efficient, eco-friendly

Integrated with our latest energy-saving technology: Premium drive efficiency, smart power management at times of low passenger density and selected low-power components, the Schindler 9300AE is one of the most efficient escalators in retail applications.

▶▶▶ Superb performance, global service

With its high-grade, low-wear-and-tear components, the Schindler 9300AE escalator is a product with superb quality and performance. Wherever you are, Schindler global services protect your long-term investment.

▶▶▶ Elegant adaptable design options

The Schindler 9300AE escalator offers you not only timeless basic equipment but also highly distinctive customized design options, which make it easily adaptable to smaller commercial areas and high-end shopping centers.

Your safety, our responsibility

At Schindler, safety comes first. This has been our company's motto over 100 years – and it always will be! Schindler cares about every single passenger: With the highest standards in the industry we ensure each passenger enjoys a safe ride.

From system-related safety solutions ...

MICONIC F – intelligent

microprocessor controller: Two independent safety circuits control each safety device in real time. Double check means double safety. A unique safety feature from Schindler.

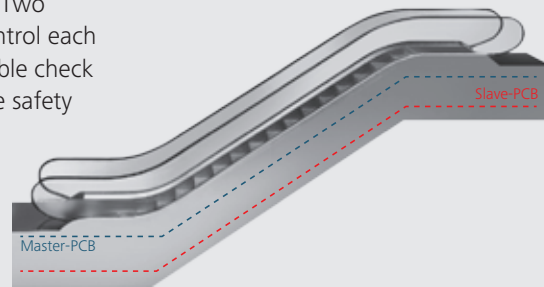

Anti-reversal check:

Speed and direction are monitored on the 1 motor shaft, 2 step band and 3 handrail.

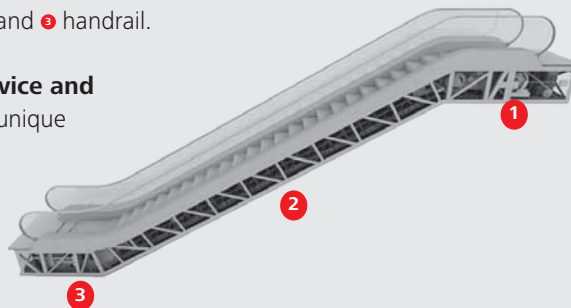

Electric anti-reversing device and

phase monitoring: These unique features prevent inadvertent direction changes.

... to the powerful components ...

Step – strongest and safest step on the market:

Schindler aluminum steps set the highest standard in the industry. Guarantee safe rides even after years in operation.

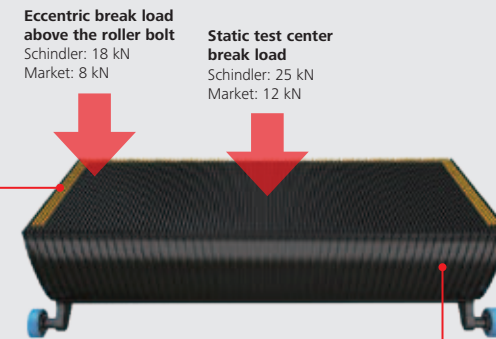

Eccentric break load above the roller bolt
Schindler: 18 kN
Market: 8 kN

Static test center break load
Schindler: 25 kN
Market: 12 kN

Schindler yellow step demarcation (optional):

- Resistant against synthetic oil
- Fire-resistant, Class V0
- Mounted without screws

Schindler compact step:

- Single piece aluminum, superior safety without screw connections
- Anti-corrosion

Do you know Schindler is the only company in the industry to produce escalator steps in-house? All steps have to pass the regular static breaking load test and eccentric breaking load above the roller pin before they leave the factory, which exceeds EN 115-1 requirements.

... to the most comprehensive safety package in the industry.

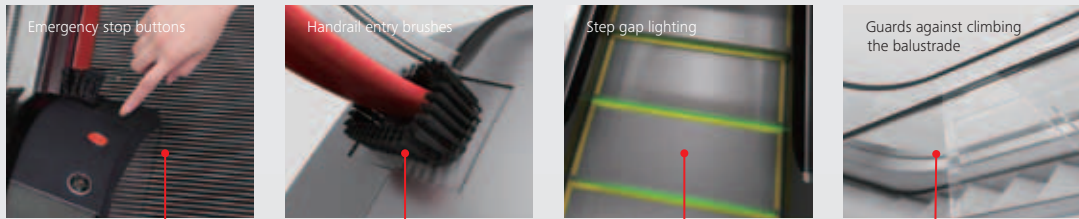

Would you like more information on safety?
Please consult the Schindler escalator safety brochure: State of the Art.

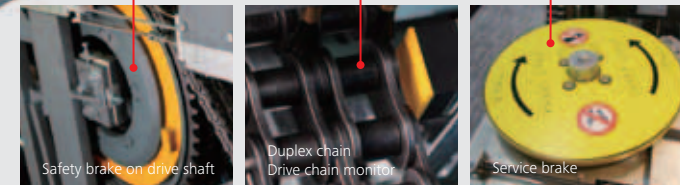
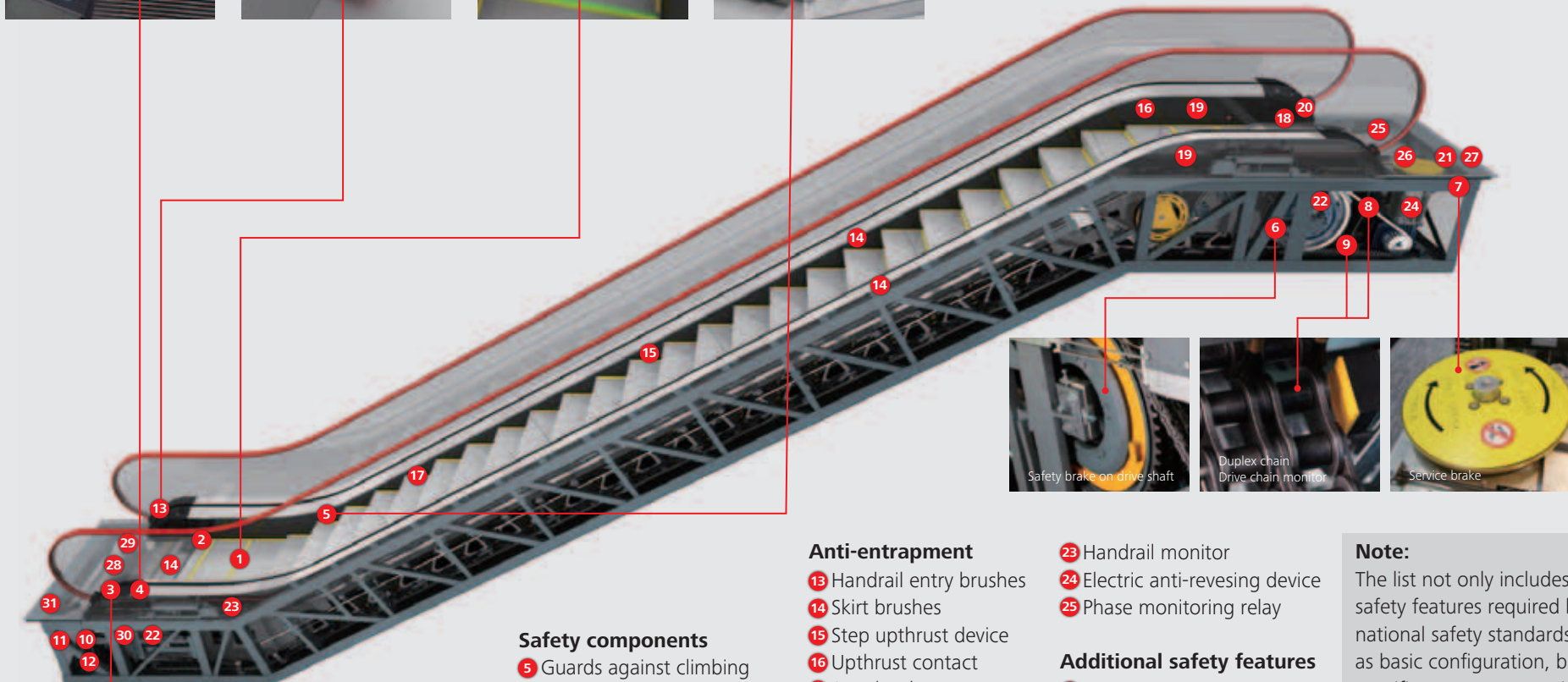

Safety indicators

- 1 Step gap lighting
- 2 Combplate lighting
- 3 Direction indicators
- 4 Emergency stop button

Safety components

- 5 Guards against climbing the balustrade
- 6 Safety brake on drive shaft
- 7 Service brake
- 8 Duplex chain
- 9 Drive chain monitor
- 10 Step chain tension contacts
- 11 Guard plates
- 12 Countertrack

Anti-entrapment

- 13 Handrail entry brushes
- 14 Skirt brushes
- 15 Step upthrust device
- 16 Upthrust contact
- 17 Step level contact
- 18 Combplate contacts
- 19 Skirt contacts
- 20 Handrail entry contacts

Anti-reversal

- 21 Speed monitor
- 22 Step monitor

- 23 Handrail monitor

- 24 Electric anti-reversing device
- 25 Phase monitoring relay

Additional safety features

- 26 Motor protection
- 27 Brake lining monitor
- 28 Fire contact
- 29 Smoke detector
- 30 Water level contact
- 31 Floor cover contact

Note:

The list not only includes all safety features required by national safety standards as basic configuration, but specifies even more optional extras.

Energy-efficient, eco-friendly

The Schindler 9300AE escalator features three design solutions that increase energy efficiency: more efficient drive systems, components requiring less power, and intelligent power management software. We call it the Schindler E³ energy-saving approach.

E³ – Schindler's unique energy-saving approach





Would you like more information on efficiency? Please consult the Schindler escalator efficiency brochure: Performance is not a question of consumption.

Choose your ECOLINE package*:

ECOLINE	ECO 	ECO Plus 	ECO Premium 	ECO Premium Plus 
Energy consumption [▲]	-3,001 kWh -25% 	-4,273 kWh -36% 	-3,888 kWh -32% 	-4,196 kWh -35% 
Operating mode	Continuous operation with ECO power feature: Motor power adjusts based on passenger load	Stop-and-go operation with ECO power feature: Escalator stops when no passengers are on it	Slow-speed operation with ECO power feature: Escalator slows down when no passengers are on it	Stop-and-go and slow-speed operation with ECO power feature: Escalator stops after an adjustable time running in slow speed.
Application	For continuous medium to heavy passenger traffic	Intermittent flow including periods of zero passenger flow Non-commercial applications	Intermittent flow including periods of zero passenger flow Commercial applications	Intermittent flow including periods of zero passenger flow Commercial and non-commercial applications
Benefits	<ul style="list-style-type: none"> • Maintains passenger flow • Power consumption reduced by up to 25% • Reduced power plant CO₂ emissions • Short amortization period 	<ul style="list-style-type: none"> • Power consumption reduced by up to 36% • Reduced power plant CO₂ emissions • Increased escalator lifespan 	<ul style="list-style-type: none"> • Passenger flow maintained, as escalator is in motion when passengers approach it • Power consumption reduced by up to 32% • Reduced power plant CO₂ emissions • Reduced wear & tear on components 	<ul style="list-style-type: none"> • Passenger flow maintained, as escalator is in motion when passengers approach it • Power consumption reduced by up to 35% • Reduced power plant CO₂ emissions • Reduced wear & tear on components • Increased escalator lifespan
CO ₂ footprint	Minus 4,500 kg per year	Minus 6,410 kg per year	Minus 5,830 kg per year	Minus 6,290 kg per year
Amortization*	Less than 0.5 year	Less than 1.5 years	Less than 2 years	Less than 2 years

* Values based on theoretical calculations for one Schindler 9300AE-10 escalator. Average value for up and down operated escalator pair: 4.5 m. Step width: 1,000 mm. Speed: 0.5 m/s. Load profile: 11 hours per day, 365 days per year. 2.5 hrs – 0%. 7 hrs – 25%. 1 hr – 50%. 0.5 hrs – 75%. 0 hrs – 100%.

▲) Standard operating mode: 11,967 kWh, 100% continuous running.
 •) Amortization depending on national energy cost.

Superb performance, global service

With its high-grade, low-wear-and-tear components, the Schindler 9300AE escalator is a product with superb quality and performance. Wherever you are, Schindler global services protect your long-term investment.

Superb performance comes from stringent design

Smooth operation: Schindler uses hydrolysis-resistant polyurethane step rollers, the most reliable rollers on the market, which ensure smooth operation even in tropical and subtropical regions.



Long service life: Schindler is committed to designing for a service life of over 20 years, such as in the microprocessor-controlled lubrication system, which feeds the precise amount of lubricant to every lubrication point, thus ensuring a long service life for all mechanical components.

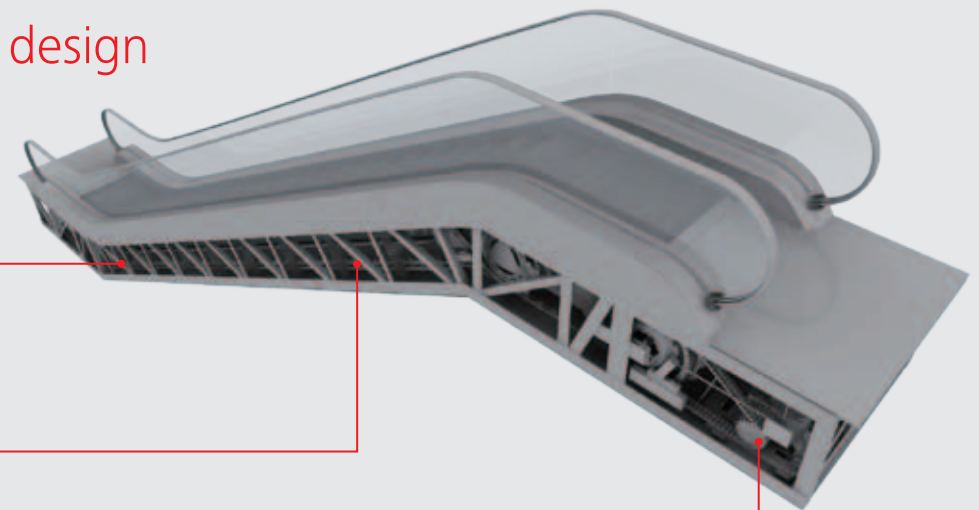

Quiet running – quiet drive units
The Schindler 9300AE is quieter in operation than other leading commercial escalator brands.



Long-term returns start with high-quality products and services

Unified global production system boasts European design concepts

Across the globe, Schindler operates nine production units for escalators and key escalator components like steps, trusses, and controllers. The Shanghai Works factory is by far the biggest escalator plant in the industry. All our factories comply with global assembly and quality standards.

Customer-focused maintenance service

Schindler not only has a standard and strict maintenance process, but also global spare parts supply. Maintaining your escalator using Schindler-manufactured spare parts, you can be confident it will stay in excellent working order.

Integrated TQM system ensures excellence in quality

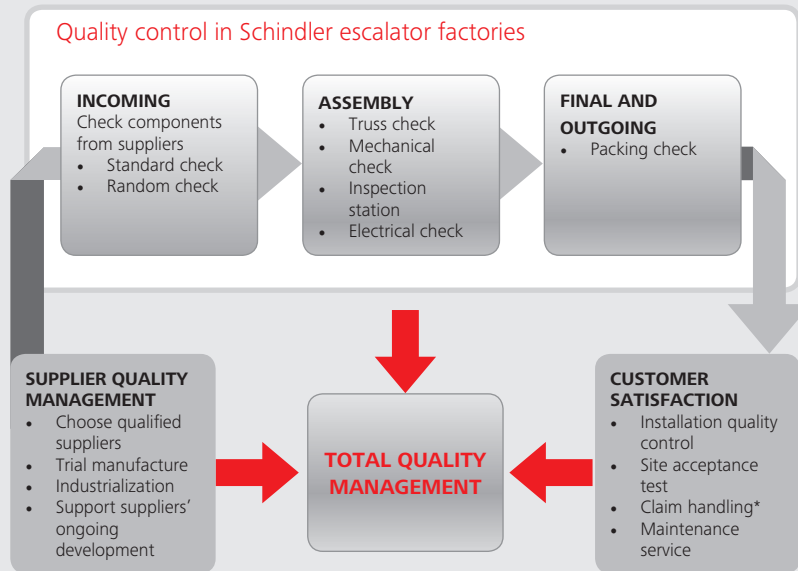











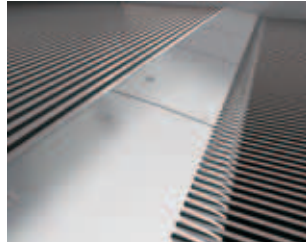

*) In case of claims for damaged or missing components, the factory's special claims handling team will help you analyze them.

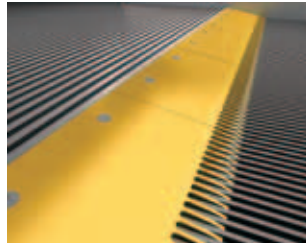

Elegant adaptable design options

The Schindler 9300AE escalator offers you not only timeless basic equipment, but also highly distinctive customized design options that make it easily adapted to smaller commercial areas and high-end shopping centers.

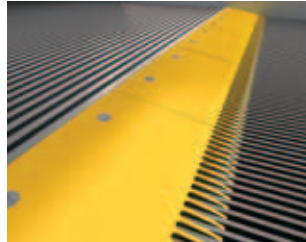
Step	Inner/outer decking	Comb	Floor cover	Balustrade type	
					
Aluminum, natural finish	Aluminum, powder-coated, RAL 9006	Aluminum, powder-coated, RAL 9002	Aluminum, natural finish	Stainless steel, square pattern	E-type
					
Silver	Aluminum, powder-coated, RAL 1013	Aluminum, powder-coated, RAL 3004	Aluminum, powder-coated, yellow	Aluminum, lined pattern	
					
Black with yellow synthetic demarcations	Aluminum, powder-coated, RAL 7030	Stainless sheet steel	Full color polycarbonate comb		



Nothing is unchangeable in our design lines. Our favorite designs just give you an idea of what is possible and can be easily combined. If you like to be more creative, you can even completely design your own escalator.

Joins type

LED lighting

Handrail

Skirt panel

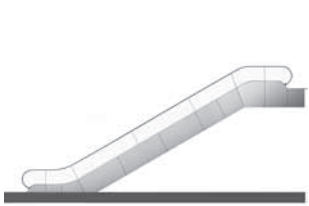

Standard

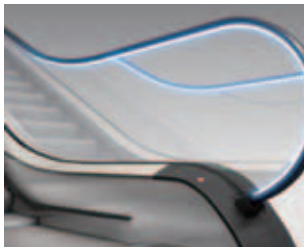

E balustrade lighting

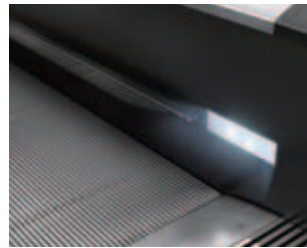

Comb lighting



Black

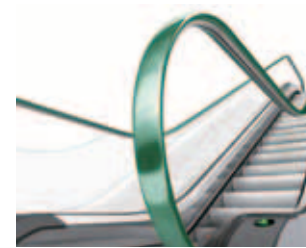

Green

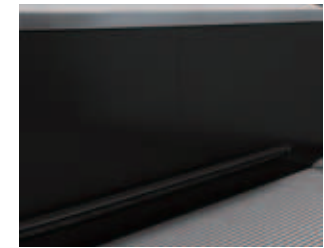

Sheet steel,
black anti-friction

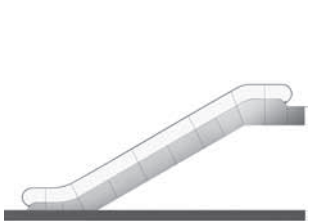

Optical



Skirt lighting with spots

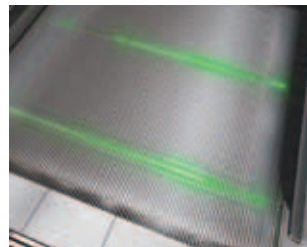

Step gap lighting



Red



Orange



Stainless steel

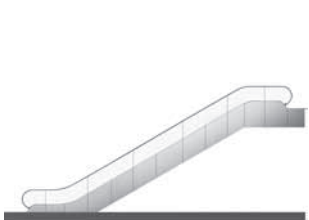

Vertical



Skirt lighting with light strip

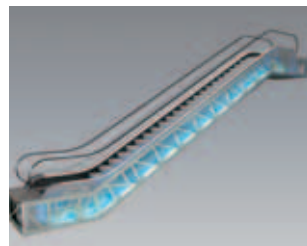

Truss lighting

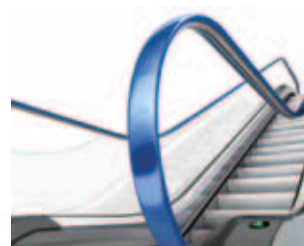

Blue

Note:

Specifications, options, and colors are subject to change. All options illustrated in this brochure are representative only. The samples shown may vary from the original in color and material.



PROJECT: Mix city

Location: Shenyang, China

Units: 79

Rise: from 3 m to 12.5 m



Schindler 9300AE

Planning data

Nominal step width [mm]	Angle of inclination [degrees]	Max. rise H [m]	Speed [m/s]	Installation
600	30.0 35.0	12	0.5	Indoor Outdoor-covered Outdoor
800	27.3 30.0 35.0	24	0.5 0.6 0.65	Indoor Outdoor-covered Outdoor
1,000	27.3 30.0 35.0	20	0.5 0.6 0.65	Indoor Outdoor-covered Outdoor



Interactive configuration with SchindlerDraw

For project-specific configurations we recommend

SchindlerDraw, the interactive online configuration tool

available at

www.schindler.com.

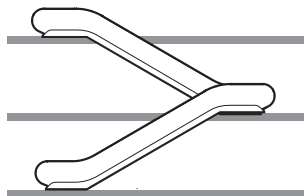

Continuous arrangement
(one-way traffic)

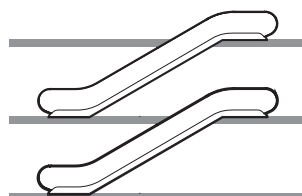

Interrupted arrangement
(one-way traffic)

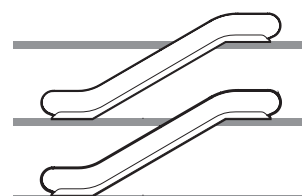

Parallel interrupted arrangement
(two-way traffic)

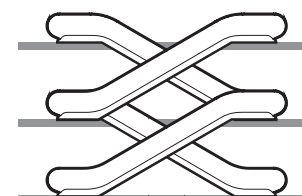

Crisscross continuous arrangement
(two-way traffic)

Schindler 9300 Advanced Edition

Type 10 • 30°-K

Rise: max. 6 m at a step width of 1,000 mm

Balustrade: design E

Balustrade height: 900 / 1,000 mm

Inclination: 30°

Step width: 600 / 800 / 1,000 mm

Step run: 2 horizontal steps

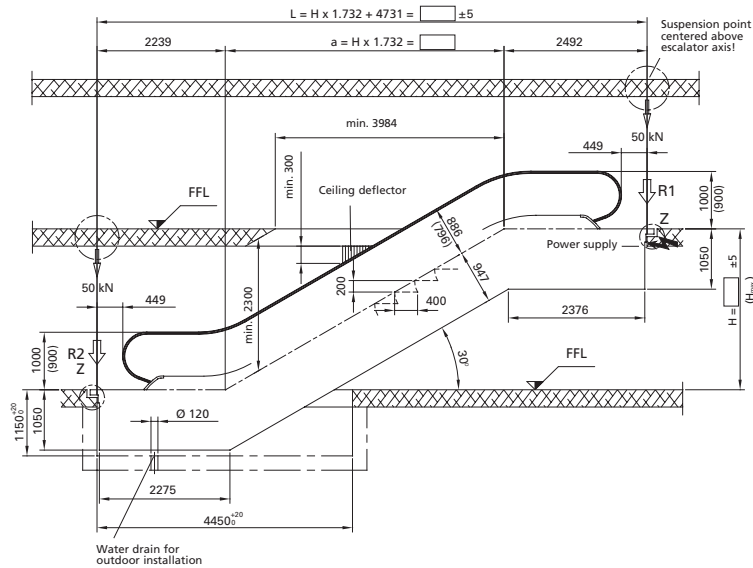

Transportation dimensions

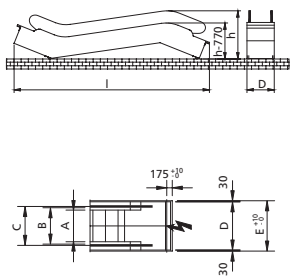

Detail Z

Gaps at joints to be filled with joint filler (by customer)

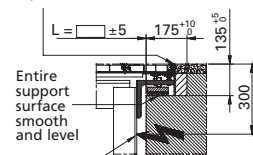

Inlet for lighting and power circuits centered at upper end, through front face

NOTES

Step width [mm]	600	800	1,000
A: Step width	600	800	1,000
B: Width between handrails	758	958	1,158
C: Handrail center distance	838	1,038	1,238
D: Width of escalator	1,140	1,340	1,540
E: Width of pit	1,200	1,400	1,600
H_{max}: Maximum rise	6,000	6,000	6,000

Step width A [mm]	Rise H [mm]	Weight [kN]	Support loads		Transp. dimensions Balustrade height 1,000	
			R1 [kN]	R2 [kN]	h [mm]	l [mm]
600	3,000	52	44	38	2,740	10,860
	3,500	56	47	41	2,760	11,850
	4,000	59	50	44	2,780	12,840
	4,500	62	53	47	2,800	13,840
	5,000	65	56	50	2,820	14,830
	5,500	69	58	53	2,830	15,830
800	3,000	55	50	45	2,740	10,860
	3,500	59	54	48	2,760	11,850
	4,000	62	57	52	2,780	12,840
	4,500	66	61	55	2,800	13,840
	5,000	69	64	58	2,820	14,830
	5,500	73	68	62	2,830	15,830
1,000	3,000	59	57	51	2,740	10,860
	3,500	62	61	55	2,760	11,850
	4,000	66	65	59	2,780	12,840
	4,500	70	69	63	2,800	13,840
	5,000	73	73	67	2,820	14,830
	5,500	85	82	74	2,830	15,830
6,000	89	86	79	2,840	16,820	

All dimensions in mm.
Observe national regulations!
Subject to change.

Schindler 9300 Advanced Edition

Type 10 • 30°-M

NOTES

Rise: max. 8 m at a step width of 1,000 mm
Balustrade: design E

Balustrade height: 900 / 1,000 mm
Inclination: 30°

Step width: 600 / 800 / 1,000 mm
Step run: 3 horizontal steps

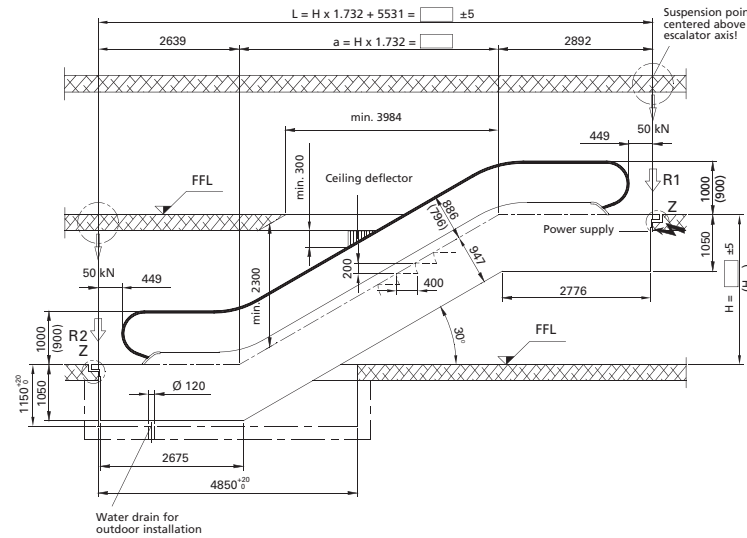

Transportation dimensions

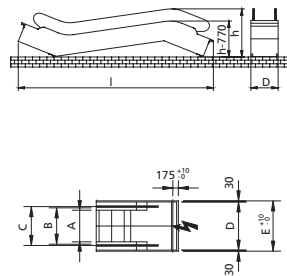

Detail Z

Gaps at joints to be filled with joint filler (by customer)

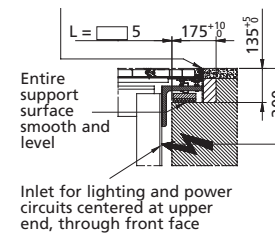

All dimensions in mm.
 Observe national regulations!
 Subject to change.

1) If $L > L_{max}$, an intermediate support may be required. Please consult Schindler.
 2) Delivery in 2 parts.

Step width [mm]	600	800	1,000
A: Step width	600	800	1,000
B: Width between handrails	758	958	1,158
C: Handrail center distance	838	1,038	1,238
D: Width of escalator	1,140	1,340	1,540
E: Width of pit	1,200	1,400	1,600
L_{max}¹⁾: Limiting span length	19,300	17,600	16,200
H_{max}: Maximum rise	12,000	9,300	8,000

Step width A [mm]	Rise H [mm]	Weight [kN]	Support loads		Transp. dimensions Balustrade height 1000	
			R1 [kN]	R2 [kN]	h [mm]	l [mm]
600	3,000	58	48	42	2,850	11,610
	3,500	61	51	45	2,880	12,590
	4,000	65	54	48	2,910	13,580
	4,500	68	57	51	2,930	14,570
	5,000	72	60	54	2,950	15,570
	5,500	75	63	57	2,970	16,560
800	6,000	78	66	60	²⁾	²⁾
	3,000	61	55	49	2,850	11,610
	3,500	65	58	53	2,880	12,590
	4,000	68	62	56	2,910	13,580
	4,500	72	65	60	2,930	14,570
	5,000	76	69	63	2,950	15,570
1,000	5,500	82	74	68	2,970	16,560
	6,000	86	78	72	²⁾	²⁾
	3,000	65	62	56	2,850	11,610
	3,500	69	66	61	2,880	12,590
	4,000	73	70	65	2,910	13,580
	4,500	79	76	70	2,930	14,570
1,000	5,000	83	80	74	2,950	15,570
	5,500	90	87	79	2,970	16,560
	6,000	94	91	83	²⁾	²⁾

Schindler 9300 Advanced Edition

Type 20 • 30°-M

NOTES

Rise: max. 13 m at a step width of 1,000 mm
Balustrade: design E

Balustrade height: 900 / 1,000 mm
Inclination: 30°

Step width: 800 / 1,000 mm
Step run: 3 horizontal steps

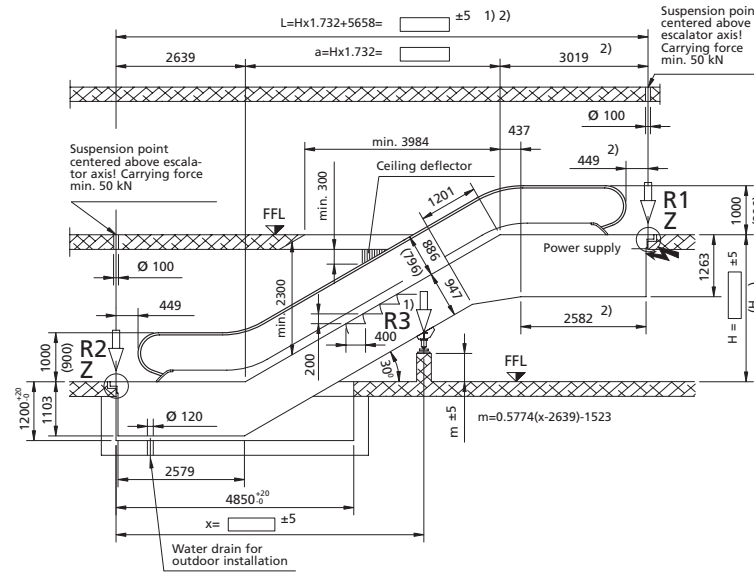

Step width [mm]	800	1,000
A: Step width	800	1,000
B: Width between handrails	958	1,158
C: Handrail center distance	1,038	1,238
D: Width of escalator	1,340	1,540
E: Width of pit	1,400	1,600
L_{max} ¹⁾ : Limiting span length	17,300	15,900
H_{max} : Maximum rise	13,000	13,000

Transportation dimensions

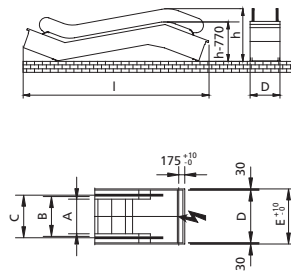

Detail Z

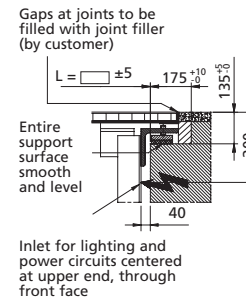

Step width A [mm]	Rise H [mm]	Weight [kN]	Support loads			Transp. dimensions Balustrade height 1,000	
			R1 [kN]	R2 [kN]	R3 [kN]	h ³⁾ [mm]	l [mm]
800	9,000	111	53	44	104	4)	4)
	10,000	119	56	47	114	4)	4)
	11,000	126	59	49	123	4)	4)
	12,000	133	61	52	133	4)	4)
	13,000	147	67	58	142	4)	4)
1,000	9,000	118	60	50	121	4)	4)
	10,000	126	63	53	132	4)	4)
	11,000	140	69	60	142	4)	4)
	12,000	154	78	63	154	4)	4)
	13,000	163	81	66	165	4)	4)

All dimensions in mm.
 Observe national regulations!
 Subject to change.

- 1) If $L > L_{max}$, an intermediate support may be required. Please consult Schindler.
- 2) With a double drive, the truss must be extended by 417 mm.
- 3) With a balustrade height of 900 mm, h is reduced by 70 mm.
- 4) Delivery in at least 2 parts.
- 5) Delivery in at least 3 parts.

Schindler 9300 Advanced Edition

Type 30 • 30°-M

Rise: max. 20 m at a step width of 1,000 mm

Balustrade: design E

Balustrade height: 1,000 mm

Inclination: 30°

Step width: 800 / 1,000 mm

Step run: 3 horizontal steps

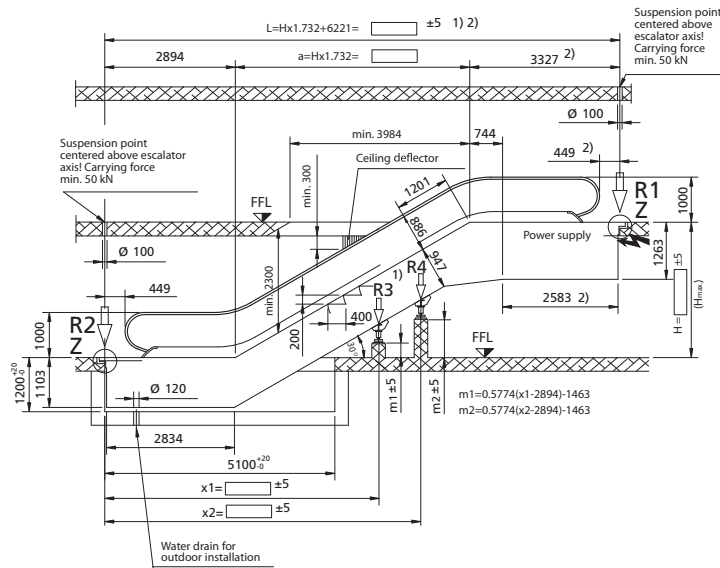

Transportation dimensions

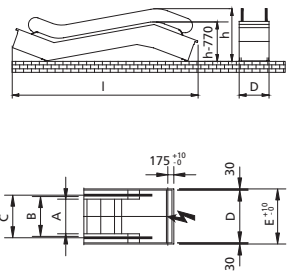

Detail Z

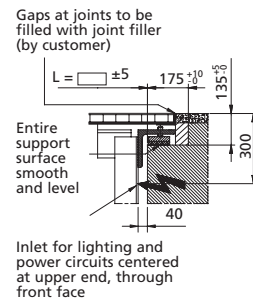

All dimensions in mm.
Observe national regulations!
Subject to change.

NOTES

Step width [mm]	800	1,000
A: Step width	800	1,000
B: Width between handrails	958	1,158
C: Handrail center distance	1,038	1,238
D: Width of escalator	1,340	1,540
E: Width of pit	1,400	1,600
L_{max}: Limiting span length	17,100	15,700
H_{max}: Maximum rise	20,000	20,000

Step width A [mm]	Rise H [mm]	Weight [kN]	Support loads				Transp. dimensions Balustrade height 1,000	
			R1 [kN]	R2 [kN]	R3 [kN]	R4 [kN]	h [mm]	l [mm]
800	14,000	159	71	62	156	-	3)	3)
	16,000	172	65	41	106	113	3)	3)
	18,000	187	65	45	117	124	3)	3)
	20,000	201	69	49	127	135	3)	3)
	22,000	227	76	55	142	149	3)	3)
1,000	14,000	167	62	43	111	118	3)	3)
	16,000	191	73	47	118	140	3)	3)
	18,000	208	74	54	139	146	3)	3)
	20,000	224	79	59	152	159	3)	3)

- 1) If $L > L_{max}$, an intermediate support may be required. Please consult Schindler.
- 2) With a double drive, the truss must be extended by 417 mm.
- 3) Delivery in at least 3 parts.
- 4) Delivery in at least 4 parts.





2 Singapore



3 Kuala Lumpur, Malaysia



4 Hong Kong

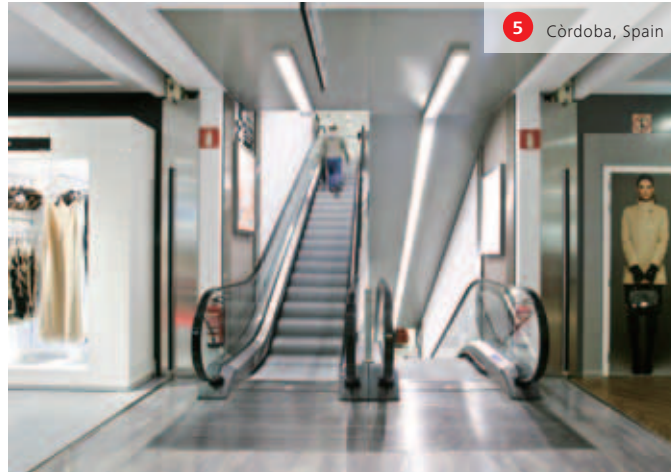

5 Córdoba, Spain



6 Rome, Italy

Where you can find the Schindler 9300AE

1 Shanghai, China	Shanghai International Finance Center	70 units	Rise from 3.4 m to 11 m
2 Singapore	ION Orchard	57 units	Rise from 3.8 m to 14.8 m
3 Kuala Lumpur, Malaysia	KLCC Lot C	8 units	Rise from 3.63 m to 5.5 m
4 Hong Kong	Times Square	59 units	Rise from 4.5 m to 10.2 m
5 Córdoba, Spain	El Corte Inglés, Córdoba	20 units	Rise from 3.3 m to 4.5 m
6 Rome, Italy	Euroma 2	22 units	Rise from 2.8 m to 5 m



To learn more of our project references, check out www.schindler.com.

From the subway to the skyline. Providing urban mobility.

Mobility is an essential requirement in the world in which we live and work. Schindler stands for urban mobility and is recognized as a hallmark of quality and safety. Every day, one billion people worldwide place their trust in Schindler products and services.

Schindler provides urban mobility with elevators, escalators, and services that are engineered for efficiency and sustainability. Schindler accompanies the development of buildings from planning and construction to daily operation, thus safeguarding their lifetime value.

Ingenious planning

Selecting the right mobility solution means analyzing the building requirements and calculating the potential traffic patterns. This is at the core of Schindler's planning support to ensure efficient mobility and a convenient journey for passengers. Bringing together global know-how for each individual project.

Schindler planning services:

- Expert consultants for traffic and product planning
- Traffic analysis and calculation service
- Specialized engineering centers for customized configurations
- Planning guidelines and tools to expedite shaft planning, building layout, and product selection/configuration

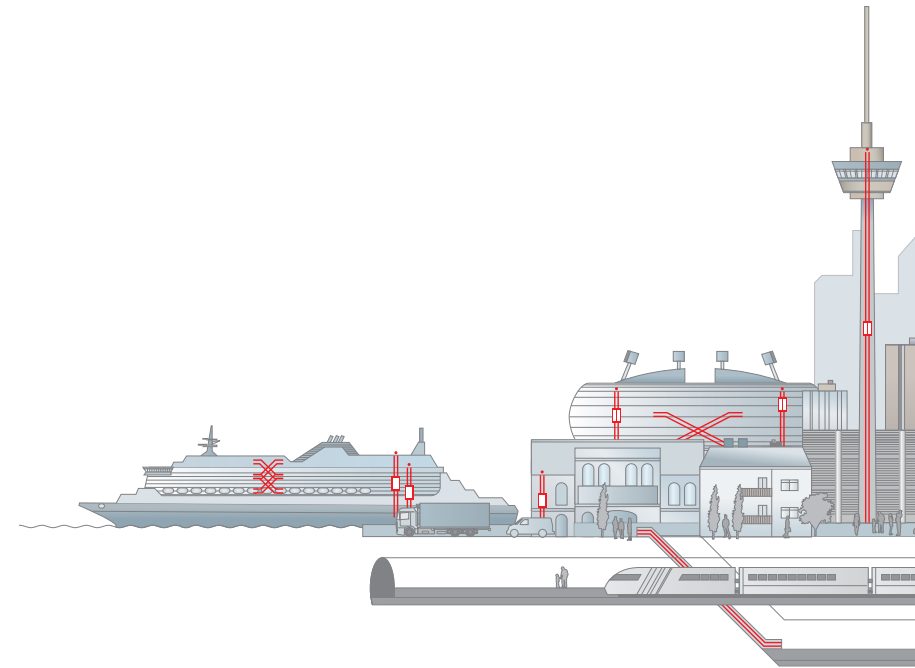

Seamless delivery

With a full-range portfolio of elevators and escalators, Schindler provides mobility solutions for any building application. Schindler customers can rely on sustainable technology, excellent project management, and profound installation methodologies. It's always the perfect fit.

Technology for all building types and mobility needs:

- Residential and office buildings
- Commercial towers, retail environments
- Hospitals and public buildings
- Heavy-traffic environments
- High-rise buildings
- Cruise liners

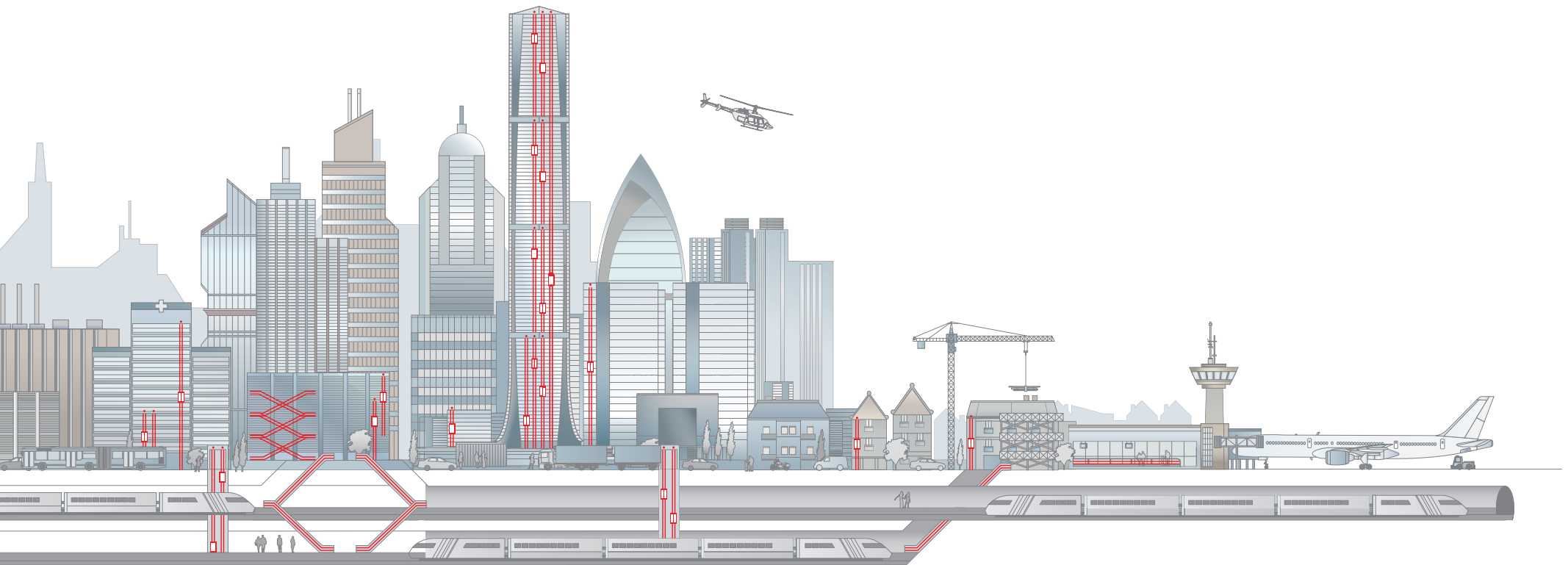

Efficient operation

Smooth, hassle-free operation, and very high availability are the result of professional maintenance and modernization. Environmental and operational efficiency add value to the investment. Reliability and sustainability – all day, every day.

The maintenance, repair, and modernization portfolio:

- Global network of branches and service points
- Skilled and certified technicians and fitters
- Service solutions for all building types and requirements
- Availability and fast delivery of spare parts
- Quickly responding call-center services
- E-monitoring diagnostic tools
- Replacement and step-by-step modernization solutions

Continuous enhancement

Schindler constantly develops new products and features to set new benchmarks and increase efficiency. Technological milestones that provide mobility to the urban society – conveniently, safely, and ecologically. Progress needs innovation.

The cutting-edge developments:

- PORT Technology – traffic, building communication, and access-control management that calculates the swiftest route through the building
- Schindler regenerative PF1 clean drive technology
- Space-saving, weight-optimized designs
- Flexible modernization concepts from full replacements to partial retrofits
- Eco-mode options for escalators and elevators

When vision meets discipline.

Schindler partners with Solar Impulse.

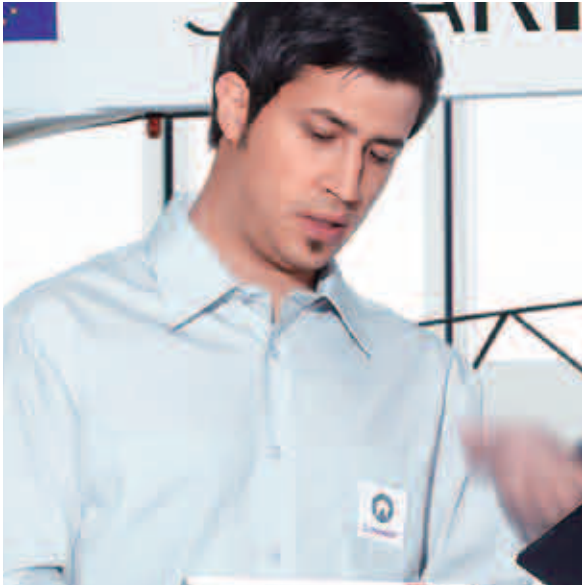

Schindler is a main partner of **Solar Impulse**, the zero-fuel airplane aiming to fly around the world propelled only by solar energy.

www.schindler.com

Legal Company Name
000 Sample Street
Sample Town 000
Sample Country

Phone 000 000 000 000
Telefax 000 000 000 000

xxx@xxx.schindler.com
www.schindler.xx

Legal Company Name
000 Sample Street
Sample Town 000
Sample Country

Phone 000 000 000 000
Telefax 000 000 000 000

xxx@xxx.schindler.com
www.schindler.xx

Legal Company Name
000 Sample Street
Sample Town 000
Sample Country

Phone 000 000 000 000
Telefax 000 000 000 000

xxx@xxx.schindler.com
www.schindler.xx

Legal Company Name
000 Sample Street
Sample Town 000
Sample Country

Phone 000 000 000 000
Telefax 000 000 000 000

xxx@xxx.schindler.com
www.schindler.xx

Legal Company Name
000 Sample Street
Sample Town 000
Sample Country

Phone 000 000 000 000
Telefax 000 000 000 000

xxx@xxx.schindler.com
www.schindler.xx